

Edelstahl

Verschraubungen

























Acier inoxydable

Raccords

Stainless steel

Unions



	Seite/Page/Page		Seite/Page/Page		Seite/Page/Page
Klemmring Bague de serrage Compression ferrule	5.4-5.7	Anschlussnippel Ecroû de raccordement mâle Nipple connection	5.19	Einstellnippel Union orientable mâle Adjustable male adaptor	5.38-5.39
					
	SO 50001		SO 51001		SO 51600
Abschlusszapfen Bouchon d'arrêt Plug	5.8	Gerade Verschraubung Union double Straight union	5.20-5.21	Reduktionsverschraubung Réduction Reduced union	5.40-5.41
					
	SO 50002		SO 51021		SO 51821
Stützhülse Douille d'appui Stiffener sleeve	5.9	Gerade Einschraubverschraubung Union mâle Male adaptor union	5.22-5.31	Winkelverschraubung Coude Elbow union	5.42-5.46
					
	SO 50003		SO 51121		SO 52021
Anschlussmutter Ecroû Union nut	5.11	Gerade Aufschraubverschraubung Union femelle Female adaptor union	5.32	Winkel-Einschraubverschraubung Coude mâle Male adaptor elbow union	5.47-5.48
					
	SO 50020		SO 51221		SO 52421
Armaturenanschluss Ecroû de raccordement Nut connection	5.12-5.14	Verbindungs-nippel Pièce folle Tube stub	5.33-5.34	Einstellwinkel Coude orientable Adjustable elbow union	5.49-5.50
					
	SO 50021		SO 51300		SO 52421
Übergangsmuffe Adaptateur femelle Female adaptor	5.15	Einstellbare Kupplung Pièce folle montée Tube stub assembly	5.35	Winkel-Schottverschraubung Coude pour passage de cloison Panel mount elbow union	5.50
					
	SO 50030		SO 51325		SO 52721
Übergangsnippel Adaptateur mâle Male adaptor	5.16-5.17	Anschweißverschraubung Union avec embout à souder Weld-on union	5.35	Schwenverschraubung METR Coude banjo METR Single banjo METR	5.51
					
	SO 50040		SO 51429		SO 52824
Schlauchtülle Douille cannelée pour tuyau Hose nozzle	5.18-5.19	Gerade Schottverschraubung Union double pour passage de cloison Panel mount union	5.36-5.37	T-Verschraubung Té Tee union	5.52-5.56
					
	SO 50503		SO 51521		SO 53021

	Seite/Page/Page
Einstellbare T und L-Verschraubung Té et L orientable Adjustable tee and L union	5.57-5.59
	SO 53621
Kreuzverschraubung Croix Cross union	5.60
	SO 54021
Doppelnippel Mamelon double Hex nipple	5.66
	AD HN 50
Doppelnippel reduziert Mamelon double réduit Hex reducing nipple	5.67
	AD HRN 50
Rohrdoppelnippel Adaptateur mâle Barrel nipple	5.67
	AD CN 50
Adapter Adaptateur Adapter	5.69
	AD A 50
Sechskant-Muffe Manchon double Hex coupling	5.74
	AD HC 50
Verschlusschraube mit Innen 6kt Bouchon d'obturation Screw Plug	5.76
	AD SP 50

	Seite/Page/Page
Verschlusschraube Vis d'extrémité Screw plug	5.76
	AD HPS 50
Aufschraub-Winkel Coude double femelle Female elbow	5.78
	AD FE 51
Einschraub-/Aufschraub-Winkel Coude femelle - mâle Street elbow	5.78
	AD SE 51
Aufschraub-T Té triple femelle Female Tee	5.78
	AD FT 51
Einschraubtülle Douille cannelée à visser Male adaptor hose nozzle	5.80
	SO 50511
Sonderausführungen:	
Exécution en option:	
Optional Services:	
	Spezialbehandlung für Einsatz mit Sauerstoff Traitement spécial pour utilisation sous oxygène Special treatment for use with oxygen
	Spezialbehandlung - silikonfrei Traitement spécial - sans silicone Special treatment - silicone free
	Spezialreinigung - entfettet Traitement spécial - sans silicone Special treatment - degreased
	Vorbeschichtete Gewinde mit Loctite 5061 Filetages pré enduits avec Loctite 5061 Pre-coated threads with Loctite 5061
	Vorbeschichtete Gewinde PTFE-Band umwickelt Filetages pré enduits avec ruban en PTFE Pre-coated threads with PTFE-tape
	Trockengeschmierte Anschlussmutter Ecroû enduit d'un lubrifiant sec Dry lubricated nut

Sonderausführung für Adapter
siehe Kapitel 9

Exécution en option pour adaptateurs
voir chapitre 9

Option services for adaptors
see chapter 9

Eigenschaften, Besonderheiten

- einfache, schnelle Montage
- korrosionsbeständig
- kompakte Bauweise
- grosse Sortimentsvielfalt
- viele Kombinationsmöglichkeiten

Funktionsprinzip

siehe Anhang

Werkstoff

Edelstahl 1.4571, Legierung X 6 CrNiMoTi 17 12 2, DIN EN 10216-5 (≈ AISI 316 Ti)

Nenndruck PN

siehe Produkttabellen (4fache Sicherheit)

Temperaturbereich

-110°C bis +300°C.

Helium - Leckrate

≤ 10⁻⁶mbar • l/s

Vakuum

Bis 10⁻⁴mbar, höhere Werte möglich.

Anzuschliessende Rohre

Kunststoffrohre und nahtlose Präzisionsrohre aus Edelstahl (DIN EN 10216-5/EN ISO 1127, Toleranzkl. T4) mit sauberer, glatter Oberfläche. Aussendurchmesser innerhalb ± 0,1 mm. Siehe auch Kapitel Rohre und Schläuche. Weitere Materialien auf Anfrage.

Werkzeugnis

Bescheinigung 2.2 nach EN 10204.

Zulassungen

DET NORSKE VERITAS, DVGW-Gas/ SVGW-Gas, Germanischer Lloyd, American Bureau of Shipping, Lloyd's Register, SIREP-WIB-EXERA
Weitere Informationen auf Anfrage.

Einschraubzapfen, Gewinde

Rohrgewinde (Zoll) und metrisches Feingewinde DIN 3852, kegelig nach Form C, zylindrisch nach Form B, mit Dichtkante nach Form E. NPT-Gewinde nach ANSI/ASME B1.20.1-1983. UNF/UN Gewinde SAE 514.

Druckauswertungsgrad in % des PN
Généralités

- montage facile et rapide
- résistant à la corrosion
- dimensions compactes
- programme étendu
- multiples possibilités de combinaisons

Principe de fonctionnement

voir annexe

Matériau

Acier inoxydable 1.4571 avec l'alliage X 6 CrNiMoTi 17 12 2, DIN EN 10216-5 (≈ AISI 316 Ti).

Pression nominale PN

voir tableaux des produits (facteur de sécurité 4).

Plage de température admissible

-110°C à +300°C.

Débit de fuite avec hélium

≤ 10⁻⁶mbar • l/s

Vide

Jusqu'à 10⁻⁴mbar, plus poussé possible.

 Tubes à utiliser

Tubes en matière plastique et tous les tubes en acier inoxydable sans soudure (selon DIN EN 10216-5/EN ISO 1127, classe de tolérance T4), avec surface propre et lisse. Le diamètre extérieur doit se situer dans une tolérance de ± 0,1 mm. Voir chapitre tubes et tuyaux. Autres matériaux sur demande.

Certificat

Selon les besoins, nous pouvons établir des certificats 2.2 selon EN 10204.

Homologations

DET NORSKE VERITAS, DVGW-gaz/ SSIGE-gaz, Germanischer Lloyd, American Bureau of Shipping, Lloyd's Register, SIREP-WIB-EXERA
Autres informations sur demande.

Embouts mâles, filetages

Filetage-gaz (BSP) et filetage métrique à pas fin DIN 3852. Conique selon forme C. Cylindrique selon forme B. Filetage d'étanchéité selon forme E. Filetage NPT selon ANSI/ASME B1.20.1-1983. Filetage UNF/UN correspondent à SAE 514.

Coefficient de pression de service admissible en % de PN
Characteristics, specialities

- easy and fast to install
- resistant to corrosion
- compact size
- extensive range
- many combination possibilities

Operating principle

see appendix

Material

Stainless steel 1.4571 with the alloy X 6 CrNiMoTi 17 12 2, DIN EN 10216-5 (≈ AISI 316 Ti).

Nominal pressure PN

see product table (safety factor 4)

Temperature range

-110°C to +300°C.

Leak rate with helium

≤ 10⁻⁶mbar • l/s

Vacuum

Up to 10⁻⁴mbar, higher values are possible.

Tubes to use

Tubes of plastic and stainless steel seamless precision tubes (to DIN EN 10216-5/EN ISO 1127, tolerance class T4) with clean smooth surface. Outside diameter of ± 0,1 mm. See also chapter tubes and hoses. Further materials on demand.

Certificates

Test certificate 2.2 to EN 10204.

Approvals

DET NORSKE VERITAS, DVGW-gas/ SVGW-gas, Germanischer Lloyd, American Bureau of Shipping, Lloyd's Register, SIREP-WIB-EXERA
Additional information on request.

Adaptor stem, male thread

British Standard Pipe (BSP) and metric fine thread DIN 3852. Tapered form C, parallel form B. Thread with sealing form E. NPT-thread according to ANSI/ASME B1.20.1-1983. UNF/UN threads in accordance with SAE 514.

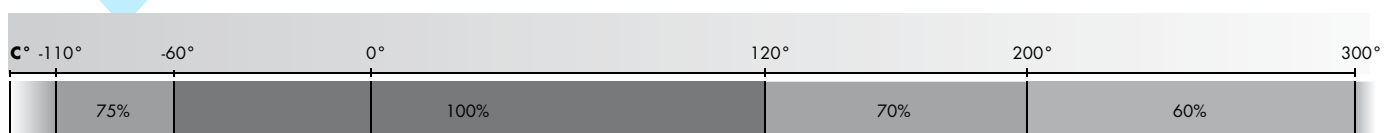
Pressure coefficient % of PN

Klemmring

Bague de serrage

Compression ferrule

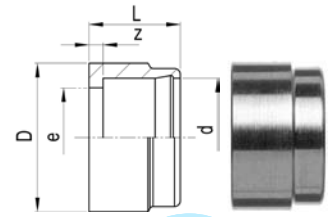

SO 50001

Type-d	Mat.-Nr.	bar	L	D	z	e	kg/100
Für metrische Rohre	Pour tubes métriques		For metric tubes				
SO 50001-2	056.0010.020	250	3.5	5.0	0.7	1.5	0.010
SO 50001-3	056.0010.030	250	4.5	5.0	0.9	2.5	0.030
SO 50001-4	056.0010.040	250	5.0	6.0	1.0	3.5	0.050
SO 50001-5	056.0010.050	250	5.5	6.8	1.1	4.0	0.060
SO 50001-6	056.0010.060	200	6.5	8.5	1.2	4.5	0.120
SO 50001-8	056.0010.080	200	7.0	10.5	1.2	6.5	0.160
SO 50001-10	056.0010.100	160	7.8	12.7	1.2	8.5	0.240
SO 50001-12	056.0010.120	160	8.8	14.7	1.2	10.0	0.310
SO 50001-15	056.0010.150	100	10.0	18.0	1.4	13.0	0.400
SO 50001-18	056.0010.180	100	11.7	22.0	1.4	16.0	0.840
SO 50001-22	056.0010.220	64	13.5	26.0	1.4	20.0	1.220
SO 50001-28	056.0010.280	40	15.4	32.5	2.0	24.0	2.150
Für Zollrohre	Pour tubes pouces		For inch tubes				
SO 50001-3,2	056.0010.032	250	4.5	5.0	0.9	2.5	0.030
SO 50001-6,35	056.0010.063	200	6.5	8.5	1.2	4.5	0.110
SO 50001-7,94	056.0010.079	200	7.0	10.5	1.2	6.5	0.160
SO 50001-9,52	056.0010.095	160	7.8	12.7	1.2	8.0	0.250
SO 50001-12,7	056.0010.127	160	10.5	18.0	1.5	11.0	0.620

Klemmring

mit integrierter Stützhülse

Bague de serrage

avec douille d'appui

Compression ferrule

with stiffener sleeve

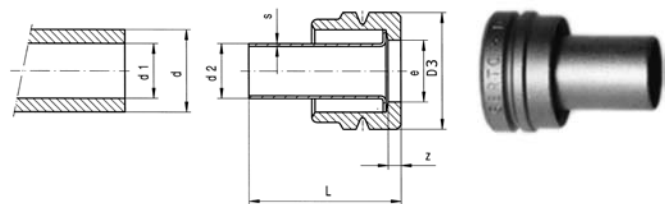

SO 50001 FIX

Type-d-d1	Mat.-Nr.	L	d2	s	z	e	D3
SO 50001-6-4 FIX	056.0015.110	11.2	4.00	0.20	1.2	4.5	8.5
SO 50001-8-6 FIX	056.0015.140	13.2	6.00	0.25	1.2	6.5	10.5
SO 50001-10-8 FIX	056.0015.190	16.2	8.00	0.30	1.2	8.5	12.7
SO 50001-12-10 FIX	056.0015.240	19.2	10.00	0.25	1.2	10.0	14.7

Klemmring

für Durchgangverschraubungen

Bague de serrage

pour conduites de mesure

Compression ferrule

for gauge lines

SO 50001 D

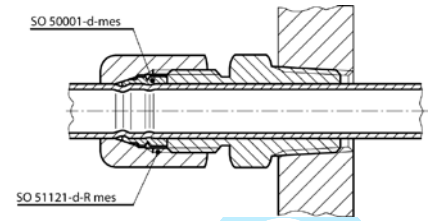

Type -d	Mat.-Nr.	bar	L	D	kg/100
SO 50001-2 D	056.0012.020	6	3.5	5.0	0.020
SO 50001-2-1 RED D	056.0012.008	6	4.5	5.0	0.020
SO 50001-2-1,5 RED D	056.0012.013	6	4.5	5.0	0.020
SO 50001-3 D	056.0012.030	6	4.5	5.0	0.030
SO 50001-3-1,6 RED D	056.0012.015	6	6.0	5.0	0.050
SO 50001-3-2,5 RED D	056.0012.043	6	4.5	5.0	0.010
SO 50001-4 D	056.0012.040	6	5.0	6.0	0.050
SO 50001-5-3 RED D	056.0012.061	6	7.5	6.5	0.120
SO 50001-5-3,5 RED D	056.0012.068	6	5.5	6.8	0.010
SO 50001-6 D	056.0012.060	6	6.5	8.5	0.100
SO 50001-8 D	056.0012.080	6	7.0	10.5	0.150
SO 50001-8-6 RED D	056.0012.140	6	9.5	10.5	0.280
SO 50001-10 D	056.0012.100	6	8.0	12.5	0.220
SO 50001-10-8 RED D	056.0012.190	6	11.5	12.5	0.340
SO 50001-12 D	056.0012.120	6	9.0	14.5	0.290
SO 50001-12-10 RED D	056.0012.240	6	12.5	14.5	0.530
SO 50001-15 D	056.0012.150	6	10.0	18.0	0.500
SO 50001-15-12 RED D	056.0012.420	6	15.0	18.0	1.020
SO 50001-18 D	056.0012.180	6	11.7	22.0	0.840
SO 50001-22 D	056.0012.220	6	13.5	26.0	1.200

Klemmringe ohne Innenbund, durch die Rohre durchgesteckt werden können, sind auch lieferbar. Abmessungen wie Klemmring SO 50001. Die Typen-Nr. ist dann mit «D» zu ergänzen, z.B. SO 50001 -d-D. Komplette Verschraubungen für Messleitungen sind auch lieferbar. Die Typen-Nr. ist dann zusätzlich mit «D» zu ergänzen, z. B. SO 51121 -8- 1/4 D.

Temperatur bis +180 °C und 6 bar.

Des bagues de serrage spéciales, sans collet intérieur, permettant le libre passage traversant du tube, sont également livrables. Dimensions comme bague de serrage SO 50001. Le numéro de type est alors à compléter de «D» p.ex. SO 50001 -d-D. Des unions complètes pour conduites de mesure sont également livrables. Le numéro de type est alors à compléter de «D», p. ex. SO 51121 -8- 1/4 D.

Température jusqu'à +180 °C et 6 bar.

Compression ferrules without inside shoulder, through which the tubing can be passed completely, e.g. gauge lines can also be supplied. Dimensions analogous to compression ferrule SO 50001. Order-No. has to be supplemented with «D», e.g. type SO 50001 -d-D. Complete Unions for gauge lines can also be supplied. Order-No. for complete union has to be supplemented with «D»; e. g. type SO 51121 -8- 1/4 D.

Temperature up to +180 °C and 6 bar.

Klemmring

für Manometeranschluss

Bague de serrage

pour écrou de manomètre

Compression ferrule

for pressure gauge connection

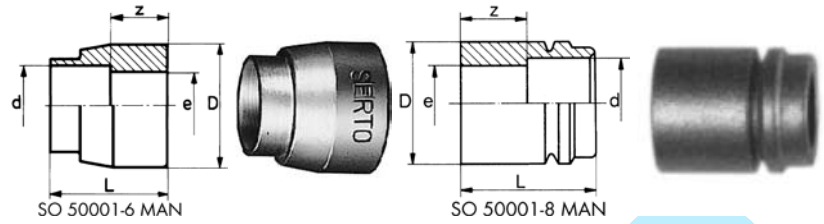

SO 50001 MAN

Type-d	Mat.-Nr.	bar	L	D	z	e	kg/100
SO 50001-6 MAN	056.0011.110	125	11.5	10.0	6.5	5.0	0.200
SO 50001-8 MAN	056.0011.185	125	11.5	12.0	5.5	6.5	0.400

Beide Dimensionen sind für 1/4" und 1/2" Gewinde geeignet.

Les deux dimensions sont utilisables pour les filetages 1/4" et 1/2" .

Both dimensions are suitable for 1/4" and 1/2" threads.

Diese Klemmringe «SO 50001 man» dürfen nur mit der Anschlussmutter für Manometer verwendet werden, deren Bestellnummer «man» enthält.

Les bagues de serrage «SO 50001 man» doivent être utilisées uniquement avec les écrous pour manomètre portant la désignation «man».

These compression ferrules «SO 50001 man» must only be used with the union nut for pressure gauges of which the order number contains «man».

Für alle anderen Manometeranschlüsse wird der Klemmring SO 50001 verwendet.

Pour d'autres dimensions, utiliser la bague de serrage SO 50001.

For all other pressure gauge connections the compression ferrule SO 50001 is to be used.

Klemmring reduziert

Bague de serrage de réduction

Reduction compression ferrule

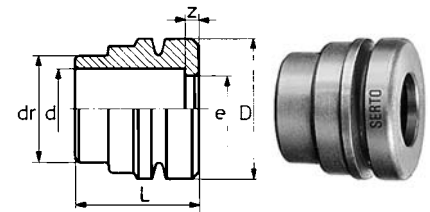

SO 50001 RED

Type-dr-d	Mat.-Nr.	bar	L	D	dr	z	e	kg/100
Für metrische Rohre	Pour tubes métriques			For metric tubes				
SO 50001-4-2 RED	056.0014.030	250	7.0	6.0	4.00	0.9	1.5	0.080
SO 50001-5-3 RED	056.0014.060	250	7.5	6.8	5.00	0.9	2.5	0.130
SO 50001-6-4 RED	056.0014.110	200	8.5	8.5	6.00	1.1	3.5	0.190
SO 50001-6-5 RED	056.0014.117	200	8.7	8.5	6.00	1.1	4.0	0.150
SO 50001-8-6 RED	056.0014.140	200	9.5	10.5	8.00	1.3	4.5	0.320
SO 50001-10-8 RED	056.0014.190	160	11.5	12.7	10.00	1.3	6.5	0.430
SO 50001-12-10 RED	056.0014.240	160	12.5	14.7	12.00	1.2	8.5	0.510
SO 50001-15-12 RED	056.0014.420	100	15.0	18.0	15.00	1.2	10.0	1.060
SO 50001-15-14 RED	056.0014.440	100	15.0	18.0	15.00	1.4	12.0	0.710
SO 50001-18-15 RED	056.0014.610	100	16.7	22.0	18.00	1.4	13.0	1.670
SO 50001-18-16 RED	056.0014.620	100	16.7	22.0	18.00	1.4	14.0	1.470
SO 50001-22-18 RED	056.0014.755	64	20.0	26.0	22.00	1.4	16.0	2.620
Für Zollrohre	Pour tubes pouces			For inch tubes				
SO 50001-3-1,6 RED	056.0014.015	250	6.2	5.0	3.00	0.8	1.0	0.090
SO 50001-5-3,2 RED	056.0014.062	250	7.5	6.8	5.00	0.9	2.5	0.115
SO 50001-8-6,35 RED	056.0014.143	200	9.5	10.5	8.00	1.3	4.5	0.300
SO 50001-10-7,94 RED	056.0014.187	160	11.5	12.7	10.00	1.3	6.5	0.430
SO 50001-15-12,7 RED	056.0014.427	100	15.0	18.0	15.00	1.4	11.0	0.940
SO 50001-15-13,5 RED	056.0014.435	100	15.0	18.0	15.00	1.4	12.0	0.840
SO 50001-18-15,88 RED	056.0014.618	100	16.7	22.0	18.00	1.4	14.0	1.470
SO 50001-18-17,2 RED	056.0014.632	100	16.7	22.0	18.00	1.4	15.0	1.160
SO 50001-22-19,05 RED	056.0014.760	64	20.0	26.0	22.00	1.4	16.0	2.480
SO 50001-22-21,3 RED	056.0014.785	64	20.0	26.0	22.00	1.4	19.5	1.470

Anwendungsbeispiele:

Exemples d'utilisation:

Sample combinations:

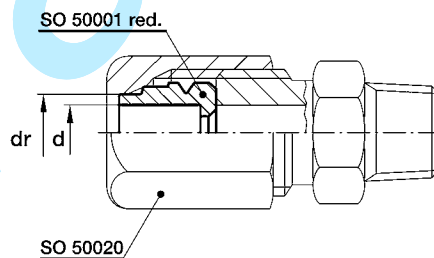

Einstufige Reduktionen von Rohranschlüssen sind auf einfachste Art durch Auswechseln der normalen gegen die reduzierten Klemmringe möglich.

Beispiel:

Reduktion eines Rohranschlusses $\varnothing 15$ mm auf $\varnothing 12$ mm: Klemmring SO 50001-15 austauschen gegen Klemmring SO 50001-15-12 RED. Anschlussmutter SO 50020-15 bleibt.

Le raccordement de tubes réduits d'une dimension peut s'effectuer très simplement en échangeant la bague de serrage normale contre une bague de réduction.

Exemple:

Réduction d'un raccord $\varnothing 15$ mm à $\varnothing 12$ mm: Echanger la bague de serrage SO 50001-15 contre une bague de réduction SO 50001-15-12 RED. L'écrou SO 50020-15 reste le même.

Single stage tube reduction connections are easily made by replacing the standard compression ferrule with a reduction compression ferrule.

Example:

Tube reduction connection $\varnothing 15$ mm to $\varnothing 12$ mm: Replace compression ferrule SO 50001-15 by compression ferrule SO 50001-15-12 RED. Union nut SO 50020-15 remains.

Abschlusszapfen

Bouchon d'arrêt

Plug

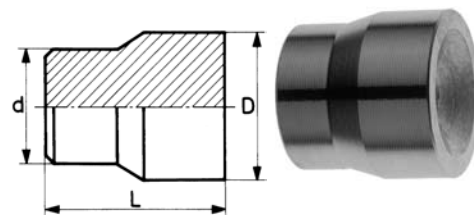

SO 50002

Type -d	Mat.-Nr.	L	D	kg/100
Für metrische Rohre	Pour tubes métriques		For metric tubes	
SO 50002-2	056.0020.020	5.5	3.6	0.040
SO 50002-3	056.0020.030	7.0	4.8	0.080
SO 50002-4	056.0020.040	8.0	6.0	0.130
SO 50002-5	056.0020.050	8.5	6.4	0.200
SO 50002-6	056.0020.060	9.5	8.3	0.310
SO 50002-8	056.0020.080	10.0	10.3	0.550
SO 50002-10	056.0020.100	13.0	12.3	0.890
SO 50002-12	056.0020.120	14.0	13.6	1.390
SO 50002-15	056.0020.150	16.5	16.6	3.100
SOL 50002-16	076.0020.160	19.0	18.5	3.380
SO 50002-18	056.0020.180	19.0	20.5	4.340
SO 50002-22	056.0020.220	22.0	24.5	6.620
SO 50002-28	056.0020.280	23.0	30.5	11.100

Für Zollrohre	Pour tubes pouces		For inch tubes	
SO 50002-6,35	056.0020.063	9.5	8.3	0.310
SO 50002-7,94	056.0020.079	10.0	10.3	0.550
SO 50002-9,52	056.0020.095	13.0	12.3	0.890
SO 50002-12,7	056.0020.127	16.5	16.6	3.100

Anwendungsbeispiele:

Exemples d'utilisation:

Sample combinations:

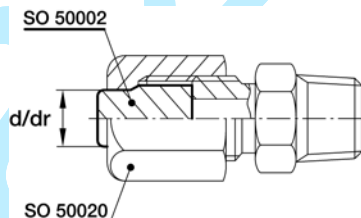

Der Abschlusszapfen SO 50002 lässt sich in jede Verschraubung anstelle eines Klemmringes gleicher Größe d einsetzen. Wird ein Klemmring SO 50001 RED durch einen Abschlusszapfen SO 50002-d ersetzt, so muss immer von der Größe dr der Anschlussmutter SO 50020 ausgegangen werden.

Le bouchon d'arrêt SO 50002 peut remplacer la bague de serrage de même dimension d dans chaque raccord. Dans le cas où un bouchon d'arrêt SO 50002-d remplace une bague de serrage SO 50001 RED il faut toujours se baser sur la dimension dr de l'écrou SO 50020.

The plug SO 50002 can be fitted into any union in place of a compression ferrule of same diameter. If a reduction ferrule SO 50001 RED is replaced by a plug SO 50002-d, the change must always be governed by the dimension dr of the union nut SO 50020.

Stützhülse

zur Rohrverstärkung

Douille d'appui

pour renforcer les tubes

Stiffener sleeve

to reinforce the tubes

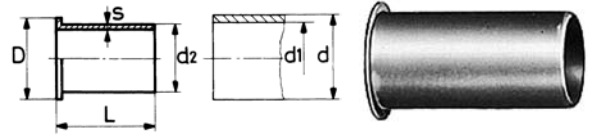

SO 50003

Type - d - d1	Mat.-Nr.	L	D	d2	s	kg/100
SO 50003-3-2	056.0030.020	6.0	2.8	2.0	0.20	0.006
SO 50003-4-2	056.0030.030	8.0	3.8	2.0	0.20	0.008
SO 50003-4-2.5	056.0030.035	8.0	3.8	2.5	0.20	0.010
SO 50003-4-3	056.0030.040	8.0	3.8	3.0	0.20	0.012
SO 50003-5-3	056.0030.060	9.0	4.5	3.0	0.20	0.013
SO 50003-5-4	056.0030.080	9.0	4.5	4.0	0.20	0.018
SO 50003-6-3	056.0030.100	10.0	5.0	3.0	0.20	0.015
SO 50003-6-4	056.0030.110	10.0	5.5	3.9	0.20	0.020
SO 50003-6-4,5	056.0030.114	10.0	5.5	4.5	0.20	0.021
SO 50003-6-5	056.0030.117	10.0	5.5	5.0	0.25	0.029
SO 50003-8-5	056.0030.136	12.0	7.5	5.0	0.25	0.040
SO 50003-8-6	056.0030.140	12.0	7.5	5.9	0.25	0.045
SO 50003-8-7	056.0030.150	12.0	7.5	6.9	0.30	0.057
SO 50003-10-7	056.0030.180	15.0	9.5	6.9	0.30	0.076
SO 50003-10-8	056.0030.190	15.0	9.5	7.9	0.30	0.088
SO 50003-10-9	056.0030.195	15.0	9.5	8.9	0.40	0.128
SO 50003-12-9	056.0030.230	18.0	11.5	8.9	0.40	0.157
SO 50003-12-10	056.0030.240	18.0	11.5	9.8	0.40	0.171
SO 50003-12-10,4	056.0030.254	18.0	11.5	10.2	0.40	0.172
SO 50003-14-12	056.0030.340	20.0	13.5	11.8	0.50	0.282
SO 50003-15-12	056.0030.420	20.0	14.5	11.8	0.50	0.282
SO 50003-15-13	056.0030.430	20.0	14.5	12.8	0.50	0.313
SO 50003-16-14	056.0030.500	22.0	15.5	13.8	0.60	0.432
SO 50003-18-14	056.0030.600	24.0	17.5	13.8	0.60	0.493
SO 50003-18-15	056.0030.610	24.0	17.5	14.8	0.60	0.531
SO 50003-18-16	056.0030.620	24.0	17.5	15.8	0.60	0.548
SO 50003-22-19	056.0030.760	28.0	21.5	18.8	0.60	0.792
SO 50003-22-20	056.0030.775	28.0	21.5	19.8	0.60	0.814
SO 50003-28-25	056.0030.910	34.0	27.5	24.8	0.60	1.260

Verstärken:

Rohre, die der radialen Einschnürung des Klemmringes ungenügenden Widerstand leisten, wie Kunststoffrohre, weiche Ne-Metallrohre, dünnwandige und weiche rostfreie Stahlrohre sind durch Stützhülsen zu verstärken.

Renforcement:

Les tubes qui présentent une résistance insuffisante à la pression d'étranglement de la bague de serrage, tels les tubes en matière plastique ou en alliages légers, ou les tubes à parois minces en acier inoxydable mou doivent être renforcés par des douilles d'appui.

Reinforcement:

Tubes which offer too little resistance to the necking of the compression ferrule, such as plastic, non-ferrous metals, thin-walled and soft stainless steel tubes are to be reinforced with stiffener sleeves.

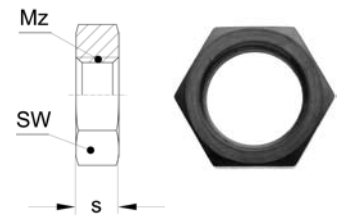
Sechskantmutter
Ecrou à six pans
Hexagon nut

SO 50006

Type -Mz	Mat.-Nr.	SW	s	kg/100
SO 50006-M6X0,75	056.0063.098	10	3.50	0.170
SO 50006-M8X1	056.0063.120	12	3.50	0.220
SO 50006-M10X1	056.0063.150	14	5.00	0.400
SO 50006-M12X1	056.0063.190	17	6.00	0.700
SO 50006-M14X1	056.0063.220	19	6.00	0.800
SO 50006-M16X1	056.0063.260	22	6.00	1.100
SO 50006-M20X1,5	056.0063.345	27	6.00	1.600
SO 50006-M24X1,5	056.0063.405	30	7.00	2.000
SO 50006-M28X1,5	056.0063.445	36	8.00	3.400

Sechskantmutter für SO 51521 + SO 51524

Ecrou à six pans pour SO 51521 + SO 51524

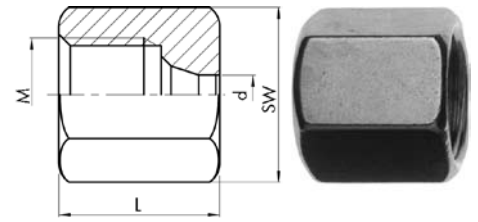
Hexagon nut for SO 51521 + SO 51524

Anschlussmutter
Ecrou
Union nut

SO 50020

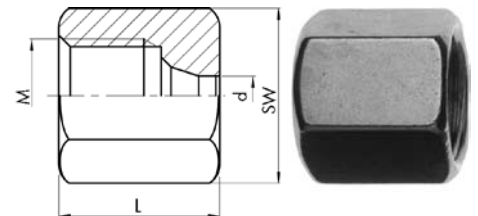
Type -d	Mat.-Nr.	bar	M	SW	L	kg/100
Für metrische Rohre	Pour tubes métriques			For metric tubes		
SO 50020-2	056.0200.020	250	6 x 0.75	8	8.5	0.200
SO 50020-3	056.0200.030	250	6 x 0.75	8	10.0	0.240
SO 50020-4	056.0200.040	250	8 x 1	10	13.0	0.490
SO 50020-5	056.0200.050	250	8 x 1	10	13.5	0.460
SO 50020-6	056.0200.060	200	10 x 1	12	15.5	0.670
SO 50020-8	056.0200.080	200	12 x 1	14	17.0	0.890
SO 50020-10	056.0200.100	160	14 x 1	17	19.5	1.540
SO 50020-12	056.0200.120	160	16 x 1	19	20.5	1.900
SO 50020-15	056.0200.150	100	20 x 1.5	24	24.0	3.810
SO 50020-18	056.0200.180	100	24 x 1.5	27	25.0	4.210
SO 50020-22	056.0200.220	64	28 x 1.5	32	28.0	6.940
SO 50020-28	056.0200.280	40	36 x 2	41	31.5	12.850
Für Zollrohre	Pour tubes pouces			For inch tubes		
SO 50020-3,2	056.0200.032	250	6 x 0.75	8	10.0	0.230
SO 50020-6,35	056.0200.063	200	10 x 1	12	15.5	0.660
SO 50020-7,94	056.0200.079	200	12 x 1	14	16.5	0.890
SO 50020-9,52	056.0200.095	160	14 x 1	17	18.5	1.560
SO 50020-12,7	056.0200.127	160	20 x 1.5	24	23.5	4.580

Anschlussmutter MAN
Ecrou MAN
Union nut MAN

SO 50020 MAN

Type -d -G	Mat.-Nr.	bar	SW	L	a	kg/100
G=Rohrgewinde (zylindrisch)	G=Filetage-gaz BSP (cylindrique)			G=BSP thread (straight)		
SO 50020-6-¼ MAN	056.0201.110	200	17	20.0	10.0	2.550
SO 50020-6-½ MAN	056.0201.125	200	24	28.0	15.0	4.820
SO 50020-8-¼ MAN	056.0201.170	200	17	24.0	10.0	2.550
SO 50020-8-½ MAN	056.0201.185	200	24	29.0	15.0	5.110
SO 50020-10-½ MAN	056.0201.285	160	24	25.5	15.0	4.400
SO 50020-12-½ MAN	056.0201.400	160	24	28.0	15.0	4.480

Armaturenanschluss

Ecrou de raccordement

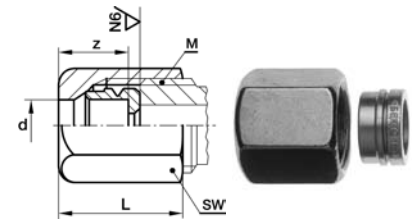
Nut connection



SO 50021

Type -d	Mat.-Nr.	bar	M	SW	L	z	kg/100
Für metrische Rohre	Pour tubes métriques	For metric tubes					
SO 50021-2	056.0210.020	250	6 x 0.75	8	8.5	4.8	0.210
SO 50021-3	056.0210.030	250	6 x 0.75	8	10.0	6.3	0.270
SO 50021-4	056.0210.040	250	8 x 1	10	13.0	7.2	0.540
SO 50021-5	056.0210.050	250	8 x 1	10	13.5	7.6	0.520
SO 50021-6	056.0210.060	200	10 x 1	12	15.5	9.5	0.790
SO 50021-8	056.0210.080	200	12 x 1	14	17.0	10.5	1.050
SO 50021-10	056.0210.100	160	14 x 1	17	19.5	13.0	1.780
SO 50021-12	056.0210.120	160	16 x 1	19	20.5	14.0	2.210
SO 50021-15	056.0210.150	100	20 x 1.5	24	24.0	16.6	4.210
SO 50021-18	056.0210.180	100	24 x 1.5	27	25.0	18.0	5.050
SO 50021-22	056.0210.220	64	28 x 1.5	32	28.0	21.4	8.160
SO 50021-28	056.0210.280	40	36 x 2	41	31.5	23.1	15.000
Für Zollrohre	Pour tubes pouces	For inch tubes					
SO 50021-3,2	056.0210.032	250	6 x 0.75	8	10.0	6.3	0.260
SO 50021-6,35	056.0210.063	200	10 x 1	12	15.5	9.3	0.770
SO 50021-7,94	056.0210.079	200	12 x 1	14	16.5	10.5	1.050
SO 50021-9,52	056.0210.095	160	14 x 1	17	18.5	12.5	1.810
SO 50021-12,7	056.0210.127	160	20 x 1.5	24	23.5	16.0	5.200

Gewindezapfen für SERTO-Anschlüsse siehe Anhang.

Embout fileté pour écrous de raccordement SERTO voir annexe.

Threaded stem for SERTO connections please see appendix.

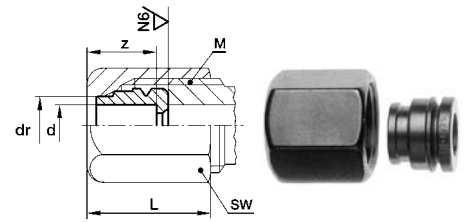
Armaturenanschluss reduziert
Ecrou de raccordement réduit
Reduction tube connection

SO 50021 RED

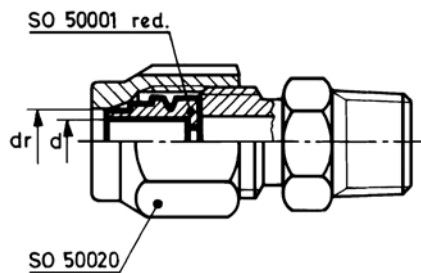
Type-dr-d	Mat.-Nr.	bar	M	SW	L	z	kg/100
Für metrische Rohre	Pour tubes métriques		For metric tubes				
SO 50021-5-3 RED	056.0214.060	250	8 x 1	10	13.5	7.8	0.590
SO 50021-6-4 RED	056.0214.110	200	10 x 1	12	15.5	9.6	0.880
SO 50021-6-5 RED	056.0214.117	200	10 x 1	12	15.5	9.6	0.840
SO 50021-8-6 RED	056.0214.140	200	12 x 1	14	17.0	10.0	1.210
SO 50021-10-8 RED	056.0214.190	160	14 x 1	17	19.5	12.6	1.970
SO 50021-12-10 RED	056.0214.240	160	16 x 1	19	20.5	14.0	2.410
SO 50021-15-12 RED	056.0214.420	100	20 x 1.5	24	24.0	16.5	4.770
SO 50021-15-14 RED	056.0214.440	100	20 x 1.5	24	24.0	16.5	4.450
SO 50021-18-15 RED	056.0214.610	100	24 x 1.5	27	25.0	18.0	5.800
SO 50021-18-16 RED	056.0214.620	100	24 x 1.5	27	25.0	18.0	5.600
SO 50021-22-18 RED	056.0214.755	64	28 x 1.5	32	28.0	21.4	10.760
Für Zollrohre	Pour tubes pouces		For inch tubes				
SO 50021-3-1,6 RED	056.0214.015	250	6 x 0.75	8	10.0	6.4	0.310
SO 50021-5-3,2 RED	056.0214.062	250	8 x 1	10	13.5	7.8	0.575
SO 50021-8-6,35 RED	056.0214.143	200	12 x 1	14	17.0	10.0	1.210
SO 50021-10-7,94 RED	056.0214.187	160	14 x 1	17	19.5	12.6	1.970
SO 50021-15-12,7 RED	056.0214.427	100	20 x 1.5	24	24.0	16.5	4.550
SO 50021-15-13,5 RED	056.0214.435	100	20 x 1.5	24	24.0	16.5	4.550
SO 50021-18-15,88 RED	056.0214.618	100	24 x 1.5	27	25.0	18.0	5.600
SO 50021-18-17,2 RED	056.0214.632	100	24 x 1.5	27	25.0	18.0	5.300
SO 50021-22-21,3 RED	056.0214.785	64	28 x 1.5	32	28.0	21.4	9.560

Anwendungsbeispiele:
Exemples d'utilisation:
Sample combinations:

Mit diesem Armaturenanschluss SO 50021 RED können einstufige Reduktionen vorgenommen werden.
Gewindezapfen für SERTO-Anschlüsse siehe Anhang.

Ces écrous de raccordement SO 50021 RED permettent d'effectuer des réductions d'une dimension.
Embout fileté pour écrous de raccordement SERTO voir annexe.

This reduction tube connection SO 50021 RED permits single stage reductions to be made.
Threaded stem for SERTO connections please see appendix.

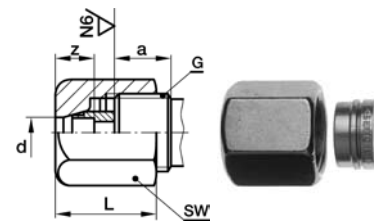
Manometeranschluss
Ecrou de manomètre
Pressure gauge connection

SO 50021 MAN

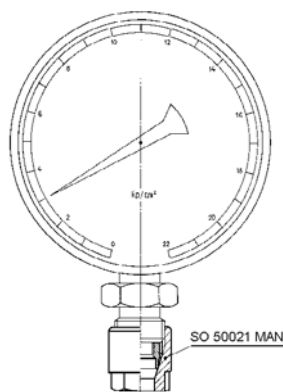
Type -d -G	Mat.-Nr.	bar	SW	L	z	a	kg/100
G=Rohrgewinde (zylindrisch)	G=Filetage-gaz BSP (cylindrique)				G=BSP thread (straight)		
SO 50021-6-¼ MAN	056.0211.110	200	17	20.0	7.0	10.0	2.750
SO 50021-6-½ MAN	056.0211.125	200	24	28.0	7.0	15.0	5.020
SO 50021-8-¼ MAN	056.0211.170	200	17	24.0	8.5	10.0	2.950
SO 50021-8-½ MAN	056.0211.185	200	24	29.0	8.5	15.0	5.510
SO 50021-10-½ MAN	056.0211.285	160	24	25.5	10.0	15.0	4.640
SO 50021-12-½ MAN	056.0211.400	160	24	28.0	11.0	15.0	4.790

Anwendungsbeispiele:
Exemples d'utilisation:
Sample combinations:

Übergangsmuffe

Adaptateur femelle

Female adaptor

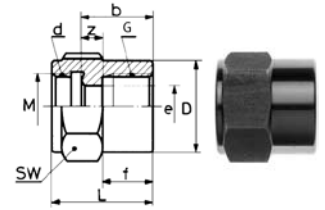

SO 50030

Type -d-G	Mat.-Nr.	bar	M	SW	L	b	D	f	z	e	kg/100
G=Rohrgewinde (zylindrisch)											
	G=Filetage-gaz BSP (cylindrique)			G=BSP thread (straight)							
SO 50030-6-1/8	056.0301.100	200	10 x 1	14	20.0	14.0	13.8	10.0	4.0	5.0	1.480
SO 50030-6-1/4	056.0301.110	200	10 x 1	17	21.0	15.0	16.8	11.0	4.0	5.0	2.350
SO 50030-6-3/8	056.0301.120	200	10 x 1	22	22.0	16.0	21.8	10.0	4.0	5.0	4.500
SO 50030-6-1/2	056.0301.125	200	10 x 1	27	24.0	18.0	26.8	11.0	4.0	5.0	7.440
SO 50030-8-1/8	056.0301.160	200	12 x 1	17	21.0	14.0	16.8	10.0	4.0	6.5	2.560
SO 50030-8-1/4	056.0301.170	200	12 x 1	17	22.0	15.0	16.8	12.0	4.0	6.5	2.150
SO 50030-8-3/8	056.0301.180	200	12 x 1	22	23.0	16.0	21.8	11.0	4.0	6.5	4.500
SO 50030-8-1/2	056.0301.185	200	12 x 1	27	25.0	18.0	26.8	13.0	4.0	6.5	7.140
SO 50030-10-1/4	056.0301.270	160	14 x 1	17	22.0	15.0	16.8	12.0	4.0	8.5	1.870
SO 50030-10-3/8	056.0301.280	160	14 x 1	22	23.0	16.0	21.8	12.0	4.0	8.5	4.050
SO 50030-10-1/2	056.0301.285	160	14 x 1	27	25.0	18.0	26.8	13.0	4.0	8.5	7.400
SO 50030-12-1/4	056.0301.380	160	16 x 1	19	22.0	15.0	18.8	11.0	4.0	8.5	3.460
SO 50030-12-3/8	056.0301.390	160	16 x 1	22	23.0	16.0	21.8	12.0	4.0	10.0	3.720
SO 50030-12-1/2	056.0301.400	160	16 x 1	27	25.0	18.0	26.8	12.0	4.0	10.0	7.030
SO 50030-15-1/4	056.0301.528	100	20 x 1.5	24	20.0	12.0	20.0	8.0	5.0	11.5	4.900
SO 50030-15-3/8	056.0301.532	100	20 x 1.5	24	25.0	17.0	23.8	12.0	5.0	13.0	5.350
SO 50030-15-1/2	056.0301.534	100	20 x 1.5	27	27.0	19.0	26.8	12.0	5.0	13.0	6.600
SO 50030-15-3/4	056.0301.536	100	20 x 1.5	32	30.0	22.0	31.8	15.0	5.0	13.0	10.400
SO 50030-18-1/2	056.0301.646	100	24 x 1.5	30	28.0	20.0	29.8	12.0	6.0	15.0	8.810

Anwendungsbeispiele:

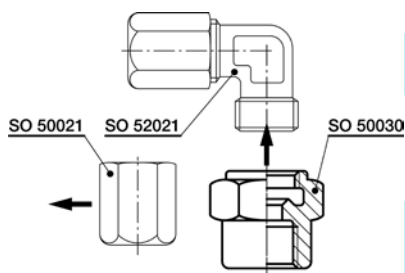

Die Übergangsmuffe SO 50030 kann an jedes SERTO Formteil mit dem passenden zylindrischen Gewinde M aufgeschraubt werden.

Dichtungsprinzip:

Bei der Montage drückt sich die Dichtkante des Übergangstückes in das SERTO-Formteil ein, dadurch entsteht eine einwandfreie metallische Dichtung. Wir empfehlen, das Gewinde mit einem geeigneten Flüssigklebstoff gegen unbeabsichtigtes lösen zu sichern.

Exemples d'utilisation:

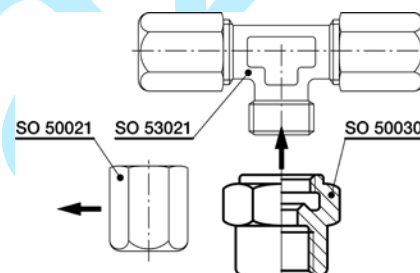

L'adaptateur femelle SO 50030 peut être monté sur toutes les pièces de forme SERTO avec le filetage cylindrique M correspondant. Principe d'étanchéité: Lors du serrage, le bourrelet s'enfonce dans la pièce de forme SERTO et donne un joint métallique parfait. Nous recommandons de freiner le filetage avec une résine appropriée contre un desserrage intempestif.

Sample combinations:

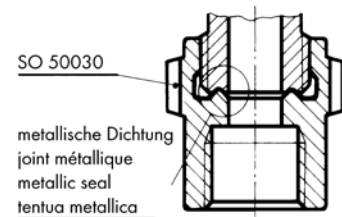

The female adaptor SO 50030 can be screwed onto every SERTO union body with the appropriate straight thread M. Sealing principle: On being installed, the lip of the adaptor presses into the SERTO union body, forming a sound metallic seal. We recommend to secure the thread with a suitable cement against unintended loosening.

Übergangsnippel NPT

Adaptateur mâle NPT

Male adaptor NPT

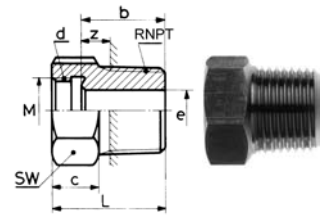

SO 50040 NPT

Type -d -RNPT	Mat.-Nr.	bar	M	SW	L	b	c	z	e	kg/100
RNPT=NPT Gewinde			RNPT=Filetage NPT					RNPT=NPT thread		
SO 50040-5-1/8 NPT	056.0402.082	250	8 x 1	10	19.0	13.0	9.0	8.9	3.5	0.820
SO 50040-6-1/8 NPT	056.0402.100	200	10 x 1	12	19.0	13.0	9.0	8.9	5.0	0.850
SO 50040-6-1/4 NPT	056.0402.110	200	10 x 1	14	23.0	17.0	9.0	11.2	4.5	1.880
SO 50040-8-1/4 NPT	056.0402.170	200	12 x 1	14	24.0	17.0	10.0	11.2	6.5	1.610
SO 50040-10-1/4 NPT	056.0402.270	160	14 x 1	17	24.0	17.0	10.0	11.2	8.5	1.680
SO 50040-10-3/8 NPT	056.0402.280	160	14 x 1	17	24.0	17.0	10.0	11.0	8.5	1.850
SO 50040-12-1/4 NPT	056.0402.380	160	16 x 1	19	25.0	18.0	11.0	12.2	8.5	2.070
SO 50040-12-3/8 NPT	056.0402.390	160	16 x 1	19	25.0	18.0	11.0	12.0	10.5	2.300
SO 50040-12-1/2 NPT	056.0402.400	160	16 x 1	22	29.0	22.0	10.0	13.9	10.5	5.330
SO 50040-15-1/2 NPT	056.0402.534	100	20 x 1.5	24	30.0	22.0	11.0	13.9	13.0	4.510

Der Übergangsnippel SO 50040 kann an jedes SERTO-Formteil mit dem passenden zylindrischen Gewinde M aufgeschraubt werden. Dichtungsprinzip: Bei der Montage drückt sich die Dichtkante des Übergangsstückes in das SERTO-Formteil ein, dadurch entsteht eine einwandfreie metallische Dichtung. Wir empfehlen, das Gewinde mit einem geeigneten Flüssigklebstoff gegen unbeabsichtigtes Lösen zu sichern.

L'adaptateur mâle SO 50040 peut être monté sur toutes les pièces de forme SERTO avec le filetage cylindrique M correspondant. Principe d'étanchéité: Lors du serrage, l'arête d'étanchéité s'enfonce dans la pièce de forme SERTO et donne un joint métallique parfait. Nous recommandons de freiner le filetage avec une résine appropriée contre un desserrage intempêtif.

The male adaptor SO 50040 can be screwed onto every SERTO union body with the appropriate straight thread M. Sealing principle: On being installed, the lip of the adaptor presses into the SERTO union body, forming a sound metallic seal. We recommend to secure the thread with a suitable cement against unintended loosening.

Übergangsnippel METR

Adaptateur mâle METR

Male adaptor METR

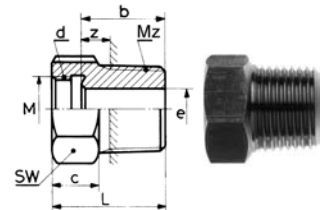

SO 50040 METR

Type -d -Mz	bar	M	SW	L	b	c	z	e	kg/100	
Mz=metrisches Gewinde (zylindrisch)			Mz=Filetage métrique (cylindrique)					Mz=Metric thread (straight)		
SO 50040-5-M6X0,75	056.0403.115	250	8 x 1	10	15.0	9.0	9.0	6.2	2.5	0.440
SO 50040-5-M8X1	056.0403.125	250	8 x 1	10	17.0	11.0	9.0	7.5	3.5	0.550

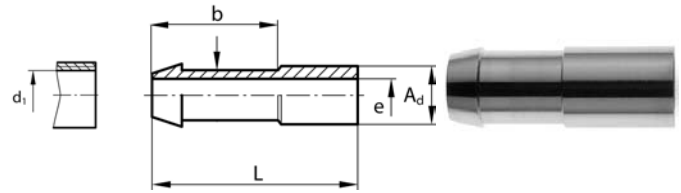
Schlauchtülle
Douille cannelée pour tuyau
Hose nozzle

SO 50503

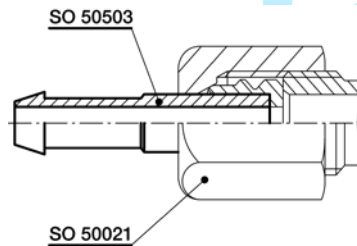
Type -Ad -d1	Mat.-Nr.	L	b	e	kg/100
SO 50503-A6-4	056.0500.110	25.0	11.0	3.0	0.250
SO 50503-A6-6	056.0500.122	31.0	17.0	4.0	0.450
SO 50503-A8-6	056.0500.140	33.0	17.0	4.0	0.470
SO 50503-A8-8	056.0500.154	33.0	17.0	6.0	0.650
SO 50503-A10-8	056.0500.190	35.0	17.0	6.0	0.660
SO 50503-A10-10	056.0500.198	37.0	19.0	8.0	1.220
SO 50503-A12-10	056.0500.240	37.0	19.0	7.0	1.160
SO 50503-A12-13	056.0500.260	39.0	21.0	9.2	1.560
SO 50503-A15-13	056.0500.430	41.0	21.0	11.0	1.810
SO 50503-A18-16	056.0500.620	47.0	26.0	13.0	2.840
SO 50503-A22-19	056.0500.760	50.0	26.0	16.0	4.170

Anwendungsbeispiele:
Exemples d'utilisation:
Sample combinations:

Mit dieser Schlauchtülle können Gummischläuche und Rohre aus Teflon, Weich-PVC, Polyamid usw. direkt an SERTO-Verschraubungen angeschlossen werden.

Exemple d'utilisation: Avec cette douille cannelée, les tuyaux en caoutchouc, les tubes en téflon, en PVC souple, en polyamide et autres peuvent être fixés directement aux raccords SERTO.

Sample combination: With this hose nozzle, rubber hoses and plastic hoses of teflon, soft PVC, polyamide can be connected directly to the SERTO unions.

d1=Rohrinnendurchmesser
Ad=Aussen-ø der Andrehung
e= kleinste Bohrung

d1=ø Intérieur du tube
Ad=ø extérieur de la portée cylindrique
e= ø-min. de passage

d1=tube inside diameter
Ad= outside diameter of cyl. Stub
e=minimum bore

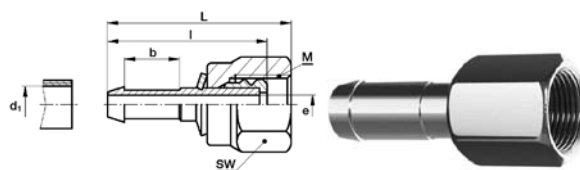
Schlauchtülle vormontiert
Douille cannelée prémontée
Hose nozzle assembly

SO 50526

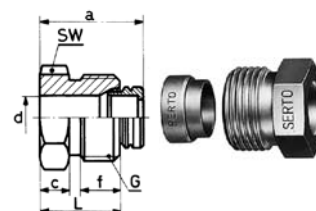
Type -Ad -d1	Mat.-Nr.	M	SW	L	b	l	e	kg/100
SO 50526-A6-4	058.0520.110	10 x 1	12	29.0	8.0	23.0	3.0	1.060
SO 50526-A6-6	058.0520.122	10 x 1	12	36.5	12.0	32.2	4.0	1.280
SO 50526-A8-6	058.0520.140	12 x 1	14	36.0	12.0	30.0	4.0	1.750
SO 50526-A8-8	058.0520.154	12 x 1	14	39.0	12.0	34.0	6.0	1.790
SO 50526-A10-8	058.0520.190	14 x 1	17	39.0	12.0	32.0	6.0	2.950
SO 50526-A10-10	058.0520.198	14 x 1	17	43.0	14.0	38.2	8.0	2.960
SO 50526-A12-10	058.0520.240	16 x 1	19	42.0	14.0	35.0	7.0	4.090
SO 50526-A12-13	058.0520.260	16 x 1	19	45.0	15.0	40.2	9.2	4.530
SO 50526-A15-13	058.0520.430	20 x 1.5	24	48.0	15.0	40.0	10.0	7.290
SO 50526-A18-16	058.0520.620	24 x 1.5	27	54.5	18.0	46.0	13.0	9.410
SO 50526-A22-19	058.0520.760	28 x 1.5	32	57.0	18.0	49.0	16.0	14.500

Anschlussnippel
Ecrou de raccordement mâle
Nipple connection

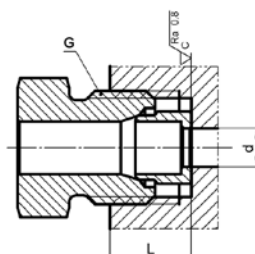
SO 51001

Type -d -G	Mat.-Nr.	bar	SW	L	a	b	c	f	t	kg/100
G=Rohrgewinde (zylindrisch)	G=Filetage-gaz BSP (cylindrique)	G=BSP thread (straight)								
SO 51001-6-¼	058.0901.110	200	14	16.0	20.2	8.3	6.0	8.0	9.5	1.470
SO 51001-8-¼	058.0901.170	200	14	14.0	19.8	9.8	6.0	6.0	11.0	1.120
SO 51001-10-¾	058.0901.280	160	17	16.0	20.8	8.8	6.0	8.0	10.0	2.000
SO 51001-12-½	058.0901.400	160	22	19.0	25.5	12.8	7.0	9.0	14.0	3.760

Anwendungsbeispiele:
Exemples d'utilisation:
Sample combinations:

d=Rohraussen-ø
 e=kleinste Bohrung
 L=Mass in montiertem Zustand
 *=mit reduziertem Klemmring

d=ø extérieur du tube
 e= ø-min. de passage
 L=après montage
 *=avec bague de serrage de réduction

d=tube outside diameter
 e=minimum bore
 L=installed length
 *=with reduction compression ferrule

Gerade Verschraubung

Union double

Straight union

SO 51021

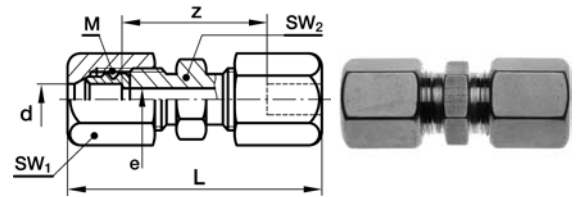

Type-d	Mat.-Nr.	bar	M	SW1	SW2	L	z	e	kg/100
Für metrische Rohre	Pour tubes métriques		For metric tubes						
SO 51021-2	058.1020.020	250	6 x 0.75	8	8	22.5	16.5	2.2	0.770
SO 51021-3	058.1020.030	250	6 x 0.75	8	8	26.5	16.5	2.2	0.850
SO 51021-4	058.1020.040	250	8 x 1	10	10	34.0	22.0	3.5	1.690
SO 51021-5	058.1020.050	250	8 x 1	10	10	34.0	22.0	3.5	1.650
SO 51021-6	058.1020.060	200	10 x 1	12	10	37.0	22.0	4.5	2.460
SO 51021-8	058.1020.080	200	12 x 1	14	12	41.5	24.5	6.5	3.350
SO 51021-10	058.1020.100	160	14 x 1	17	14	47.5	25.5	8.5	5.210
SO 51021-12	058.1020.120	160	16 x 1	19	17	50.0	26.0	10.5	6.560
* SO 51021-14	058.1020.140	100	20 x 1.5	24	22	60.0	32.0	13.0	12.680
SO 51021-15	058.1020.150	100	20 x 1.5	24	22	60.0	32.0	13.0	12.220
* SO 51021-16	058.1020.160	100	24 x 1.5	27	24	64.0	33.0	15.0	16.870
SO 51021-18	058.1020.180	100	24 x 1.5	27	24	64.0	33.0	15.0	15.760
SO 51021-22	058.1020.220	64	28 x 1.5	32	30	71.0	34.0	19.0	23.550
SO 51021-28	058.1020.280	40	36 x 2	41	36	81.0	42.0	25.0	44.500

Für Zollrohre	Pour tubes pouces		For inch tubes						
SO 51021-6,35	058.1020.063	200	10 x 1	12	10	37.0	22.0	4.5	2.420
SO 51021-9,52	058.1020.095	160	14 x 1	17	14	47.5	25.5	8.5	5.270
SO 51021-12,7	058.1020.127	100	20 x 1.5	24	22	60.0	32.0	13.0	13.100
* SO 51021-13,5	058.1020.135	100	20 x 1.5	24	22	60.0	32.0	13.0	13.000
* SO 51021-17,2	058.1020.172	100	24 x 1.5	27	24	64.0	33.0	15.0	16.260
* SO 51021-21,3	058.1020.213	64	28 x 1.5	32	30	71.0	34.0	19.0	24.750

d/d1=Rohraussen-ø
 e=kleinste Bohrung
 L=Mass in montiertem Zustand
 *=mit reduziertem Klemmring

d/d1=ø diam. extérieur du tube
 e=ø-min. de passage
 L=après montage
 *=avec bague de serrage de réduction

d/d1=tube outside diameter
 e=minimum bore
 L=installed length
 *=with reduction compression ferrule

Gerade Verschraubung reduziert

Union double réduite

Straight reduction union

SO 51021 RED

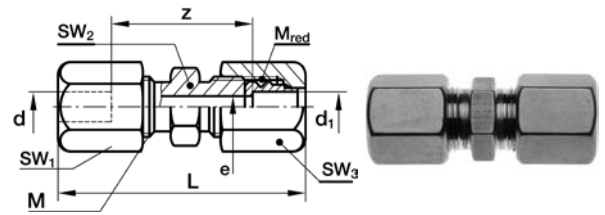

Type - d - d1	Mat.-Nr.	bar	M	M red.	SW1	SW2	SW3	L	z	e	kg/100
Für metrische Rohre	Pour tubes métriques		For metric tubes								
SO 51021-3-2 RED	058.1024.020	250	6 x 0.75	6 x 0.75	8	8	8	24.5	16.5	2.2	0.800
* SO 51021-5-3 RED	058.1024.060	250	8 x 1	8 x 1	10	10	10	34.0	22.0	35.0	1.720
* SO 51021-6-4 RED	058.1024.110	200	10 x 1	10 x 1	12	10	12	37.0	22.0	4.5	2.550
* SO 51021-6-5 RED	058.1024.117	200	10 x 1	10 x 1	12	10	12	37.0	22.0	4.5	2.510
* SO 51021-8-6 RED	058.1024.140	200	12 x 1	12 x 1	14	12	14	41.5	24.5	6.5	3.510
SO 51021-10-6 RED	058.1024.175	160	14 x 1	10 x 1	17	14	12	43.0	24.5	4.5	4.080
* SO 51021-10-8 RED	058.1024.190	160	14 x 1	14 x 1	17	14	17	47.5	25.5	8.5	4.400
* SO 51021-12-10 RED	058.1024.240	160	16 x 1	16 x 1	19	17	19	50.0	26.0	10.5	6.760
* SO 51021-15-12 RED	058.1024.420	100	20 x 1.5	20 x 1.5	24	22	24	60.0	32.0	13.0	10.780
* SO 51021-15-14 RED	058.1024.440	100	20 x 1.5	20 x 1.5	24	22	24	60.0	32.0	13.0	10.460
* SO 51021-18-15 RED	058.1024.610	100	24 x 1.5	24 x 1.5	27	24	27	64.0	33.0	15.0	16.510
* SO 51021-18-16 RED	058.1024.620	100	24 x 1.5	24 x 1.5	27	24	27	64.0	33.0	15.0	16.310
* SO 51021-22-18 RED	058.1024.755	64	28 x 1.5	28 x 1.5	32	30	32	72.0	34.0	19.0	24.920

Für Zollrohre	Pour tubes pouces		For inch tubes								
* SO 51021-5-3,2 RED	058.1024.062	250	8 x 1	8 x 1	10	10	10	34.0	22.0	35.0	2.025
SO 51021-6-6,35 RED	058.1024.119	200	10 x 1	10 x 1	12	10	12	37.0	22.0	4.5	2.440
SO 51021-10-9,52 RED	058.1024.197	160	14 x 1	14 x 1	17	14	17	47.5	25.5	8.5	5.240
SO 51021-15-12,7 RED	058.1024.427	100	20 x 1.5	20 x 1.5	24	22	24	60.0	32.0	13.0	10.660
* SO 51021-15-13,5 RED	058.1024.435	100	20 x 1.5	20 x 1.5	24	22	24	60.0	32.0	13.0	10.560
* SO 51021-18-17,2 RED	058.1024.632	100	24 x 1.5	24 x 1.5	27	24	27	64.0	33.0	15.0	16.110
* SO 51021-22-21,3 RED	058.1024.785	64	28 x 1.5	28 x 1.5	32	30	32	72.0	34.0	19.0	23.720

Weitere Reduktionen siehe SO 51821

Autres réductions voir SO 51821

Alternative reductions see SO 51821

d/d1=Rohraussen-ø
 e=kleinste Bohrung
 L=Mass in montiertem Zustand
 *=mit reduziertem Klemmring

d/d1=ø diam. extérieur du tube
 e=ø-min. de passage
 L=après montage
 *=avec bague de serrage de réduction

d/d1=tube outside diameter
 e=minimum bore
 L=installed length
 *=with reduction compression ferrule

Gerade Einschraubverschraubung

Union mâle

Male adaptor union

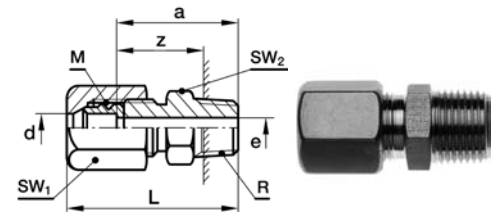

SO 51121

Type -d-R	Mat.-Nr.	bar	M	SW1	SW2	L	a	z	e	kg/100
Für metrische Rohre	Pour tubes métriques			For metric tubes						
SO 51121-2-1/8	058.1101.020	250	6 x 0.75	8	10	22.0	19.0	15.0	2.2	0.800
SO 51121-3-1/8	058.1101.040	250	6 x 0.75	8	10	24.0	19.0	15.0	2.2	0.860
SO 51121-4-1/8	058.1101.060	250	8 x 1	10	10	27.0	21.0	17.0	3.5	1.320
★ SO 51121-4-1/4	058.1101.065	200	10 x 1	12	14	34.5	27.0	21.0	4.5	2.880
SO 51121-5-1/8	058.1101.082	250	8 x 1	10	10	27.0	21.0	17.0	3.5	1.300
★ SO 51121-5-1/4	058.1101.084	200	10 x 1	12	14	34.5	27.0	21.0	4.5	2.840
SO 51121-6-1/8	058.1101.100	200	10 x 1	12	10	28.5	21.0	17.0	4.5	1.690
SO 51121-6-1/4	058.1101.110	200	10 x 1	12	14	34.5	27.0	21.0	4.5	2.790
SO 51121-6-3/8	058.1101.120	200	10 x 1	12	17	34.5	27.0	20.8	4.5	3.180
SO 51121-6-1/2	058.1101.125	200	10 x 1	12	22	39.5	32.0	24.0	4.5	5.300
SO 51121-8-1/8	058.1101.160	200	12 x 1	14	12	30.5	22.0	18.0	6.0	2.090
SO 51121-8-1/4	058.1101.170	200	12 x 1	14	14	36.5	28.0	22.0	6.5	2.980
SO 51121-8-3/8	058.1101.180	200	12 x 1	14	17	36.5	28.0	21.6	6.5	3.070
SO 51121-8-1/2	058.1101.185	200	12 x 1	14	22	41.5	33.0	24.8	6.5	5.600
SO 51121-10-1/4	058.1101.270	160	14 x 1	17	14	39.0	28.0	22.0	8.5	3.530
SO 51121-10-3/8	058.1101.280	160	14 x 1	17	17	39.0	28.0	21.8	8.5	4.640
SO 51121-10-1/2	058.1101.285	160	14 x 1	17	22	44.0	33.0	25.0	8.5	7.800
SO 51121-10-3/4	058.1101.290	100	14 x 1	17	27	46.0	35.0	27.0	8.5	12.900
SO 51121-12-1/4	058.1101.380	160	16 x 1	19	17	40.0	28.0	22.0	8.5	4.590
SO 51121-12-3/8	058.1101.390	160	16 x 1	19	17	40.0	28.0	21.8	10.5	4.790
SO 51121-12-1/2	058.1101.400	160	16 x 1	19	22	45.0	33.0	25.0	10.5	7.660
★ SO 51121-14-1/2	058.1101.504	100	20 x 1.5	24	22	49.0	35.5	27.2	13.0	8.800
SO 51121-15-3/8	058.1101.532	100	20 x 1.5	24	22	44.0	30.5	24.0	10.5	8.840
SO 51121-15-1/2	058.1101.534	100	20 x 1.5	24	22	49.0	35.5	27.2	13.0	9.030
★ SO 51121-15-3/4	058.1101.536	100	24 x 1.5	27	27	53.0	37.5	27.9	15.0	12.580
★ SO 51121-16-1/2	058.1101.566	100	24 x 1.5	27	24	52.0	36.5	28.2	13.5	11.150
★ SO 51121-16-3/4	058.1101.568	100	24 x 1.5	27	27	53.0	37.5	27.9	15.0	12.330
SO 51121-18-1/2	058.1101.646	100	24 x 1.5	27	24	52.0	36.5	28.2	13.5	10.650
SO 51121-18-3/4	058.1101.648	100	24 x 1.5	27	27	53.0	37.5	27.9	15.0	11.830
SO 51121-22-3/4	058.1101.768	64	28 x 1.5	32	30	56.5	37.5	27.9	19.0	15.490
SO 51121-28-1	058.1101.850	40	36 x 2	41	36	64.5	45.0	34.6	24.0	18.600

Für Zollrohre

Pour tubes pouces

For inch tubes

SO 51121-3,2-1/8	058.1101.045	250	6 x 0.75	8	10	24.0	19.0	15.0	2.2	0.860
SO 51121-6,35-1/8	058.1101.135	200	10 x 1	12	10	28.5	21.0	17.0	4.5	1.690
SO 51121-6,35-1/4	058.1101.140	200	10 x 1	12	14	34.5	27.0	21.0	4.5	2.790
SO 51121-6,35-3/8	058.1101.145	200	10 x 1	12	17	34.5	27.0	20.8	4.5	3.180
SO 51121-9,52-1/4	058.1101.230	160	14 x 1	17	14	39.0	28.0	22.0	8.5	3.560
SO 51121-9,52-3/8	058.1101.235	160	14 x 1	17	17	39.0	28.0	21.8	8.5	4.670
SO 51121-12,7-1/2	058.1101.434	100	20 x 1.5	24	22	49.0	35.5	27.3	13.0	9.030
★ SO 51121-13,5-1/2	058.1101.474	100	20 x 1.5	24	22	49.0	35.5	27.2	13.0	8.900
★ SO 51121-17,2-1/2	058.1101.616	100	24 x 1.5	27	24	52.0	36.5	28.2	13.5	10.850
★ SO 51121-17,2-3/4	058.1101.620	100	24 x 1.5	27	27	53.0	37.5	27.9	15.0	11.030
★ SO 51121-21,3-3/4	058.1101.738	64	28 x 1.5	32	30	56.5	37.5	27.9	19.0	16.890

d=Rohrassen-ø
 e=kleinste Bohrung
 L=Mass in montiertem Zustand
 *=mit reduziertem Klemmring

d=ø extérieur du tube
 e=ø-min. de passage
 L=après montage
 *=avec bague de serrage de réduction

d=tube outside diameter
 e=minimum bore
 L=installed length
 *=with reduction compression ferrule

Gerade Einschraubverschraubung NPT

Union mâle NPT

Male adaptor union NPT

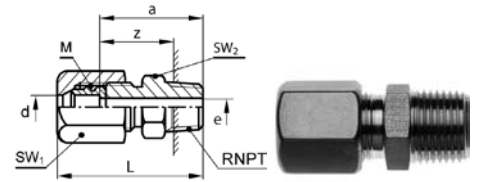

SO 51121 NPT

Type -d -RNPT	Mat.-Nr.	bar	M	SW1	SW2	L	a	z	e	kg/100
Für metrische Rohre	Pour tubes métriques			For metric tubes						
RNPT=NPT Gewinde	RNPT=Filetage NPT			RNPT=NPT thread						
SO 51121-2-1/16 NPT	058.1102.015	250	6 x 0.75	8	8	22.0	19.0	14.7	2.2	0.700
SO 51121-2-1/8 NPT	058.1102.020	250	6 x 0.75	8	12	24.0	21.0	16.6	2.2	0.900
SO 51121-3-1/16 NPT	058.1102.035	250	6 x 0.75	8	8	24.0	19.0	14.9	2.2	0.750
SO 51121-3-1/8 NPT	058.1102.040	250	6 x 0.75	8	12	26.0	21.0	16.8	2.2	1.640
SO 51121-4-1/8 NPT	058.1102.060	250	8 x 1	10	12	30.0	24.0	19.9	3.5	1.590
* SO 51121-4-1/4 NPT	058.1102.065	200	10 x 1	12	14	37.0	29.0	23.3	4.5	3.060
SO 51121-5-1/8 NPT	058.1102.082	250	8 x 1	10	12	30.0	24.0	20.0	3.5	1.570
* SO 51121-5-1/4 NPT	058.1102.084	200	10 x 1	12	14	37.0	29.0	23.3	4.5	3.020
SO 51121-6-1/8 NPT	058.1102.100	200	10 x 1	12	12	31.5	24.0	20.1	4.5	1.960
SO 51121-6-1/4 NPT	058.1102.110	200	10 x 1	12	14	37.0	29.0	23.4	4.5	2.970
* SO 51121-6-3/8 NPT	058.1102.120	200	12 x 1	14	17	38.5	30.0	24.3	6.5	2.990
* SO 51121-6-1/2 NPT	058.1102.125	200	12 x 1	14	22	44.5	36.0	28.2	6.5	3.000
SO 51121-8-1/8 NPT	058.1102.160	200	12 x 1	14	12	33.5	25.0	21.1	6.0	2.670
SO 51121-8-1/4 NPT	058.1102.170	200	12 x 1	14	14	38.5	30.0	24.4	6.5	3.150
SO 51121-8-3/8 NPT	058.1102.180	200	12 x 1	14	17	38.5	30.0	24.3	6.5	4.000
SO 51121-8-1/2 NPT	058.1102.185	200	12 x 1	14	22	44.5	36.0	28.2	6.5	5.640
SO 51121-10-1/4 NPT	058.1102.270	160	14 x 1	17	14	41.0	30.0	24.4	8.5	3.640
* SO 51121-10-3/8 NPT	058.1102.280	160	16 x 1	19	17	42.0	30.0	24.2	10.5	5.140
SO 51121-10-1/2 NPT	058.1102.285	160	14 x 1	17	22	47.0	36.0	28.0	8.5	8.270
SO 51121-12-1/4 NPT	058.1102.380	160	16 x 1	19	17	42.0	30.0	24.4	8.5	4.650
SO 51121-12-3/8 NPT	058.1102.390	160	16 x 1	19	17	42.0	30.0	24.2	10.5	4.940
SO 51121-12-1/2 NPT	058.1102.400	160	16 x 1	19	22	48.0	36.0	28.1	10.5	8.130
SO 51121-12-3/4 NPT	058.1102.405	160	16 x 1	19	27	51.0	39.0	30.6	10.5	9.000
* SO 51121-14-1/2 NPT	058.1102.504	100	20 x 1.5	24	22	52.5	38.5	30.3	13.0	9.650
SO 51121-15-1/2 NPT	058.1102.534	100	20 x 1.5	24	22	52.5	38.5	30.3	13.0	9.390
* SO 51121-16-1/2 NPT	058.1102.566	100	24 x 1.5	27	24	55.0	39.5	31.3	13.5	11.470
SO 51121-18-1/2 NPT	058.1102.646	100	24 x 1.5	27	24	55.0	39.5	31.3	13.5	15.500
* SO 51121-18-3/4 NPT	058.1102.648	64	28 x 1.5	32	30	60.5	41.5	32.8	19.0	17.460
SO 51121-22-3/4 NPT	058.1102.768	64	28 x 1.5	32	30	60.5	41.5	32.8	19.0	16.060
Für Zollrohre	Pour tubes pouces			For inch tubes						
SO 51121-3,2-1/8 NPT	058.1102.045	250	6 x 0.75	8	12	26.0	21.0	16.8	2.2	1.640
SO 51121-6,35-1/8 NPT	058.1102.135	200	10 x 1	12	12	31.5	24.0	20.1	4.5	1.960
SO 51121-6,35-1/4 NPT	058.1102.140	200	10 x 1	12	14	37.0	29.0	23.4	4.5	2.970
* SO 51121-6,35-3/8 NPT	058.1102.145	200	12 x 1	14	17	38.5	30.0	24.3	6.5	3.000
* SO 51121-6,35-1/2 NPT	058.1102.150	200	12 x 1	14	22	44.5	36.0	28.2	6.5	3.200
SO 51121-9,52-1/4 NPT	058.1102.230	160	14 x 1	17	14	41.0	30.0	24.4	8.5	3.670
SO 51121-12,7-1/2 NPT	058.1102.434	100	20 x 1.5	24	22	52.5	38.5	30.3	13.0	9.850
* SO 51121-13,5-1/2 NPT	058.1102.474	100	20 x 1.5	24	22	52.5	38.5	30.3	13.0	9.750
* SO 51121-17,2-1/2 NPT	058.1102.616	100	24 x 1.5	27	24	55.0	39.5	31.3	13.5	11.170
* SO 51121-21,3-3/4 NPT	058.1102.738	64	28 x 1.5	32	30	60.5	41.5	32.8	19.0	17.460

d=Rohrassen-ø
 e=kleinste Bohrung
 L=Mass in montiertem Zustand
 *=mit reduziertem Klemmring

d=ø extérieur du tube
 e=ø-min. de passage
 L=après montage
 *=avec bague de serrage de réduction

d=tube outside diameter
 e=minimum bore
 L=installed length
 *=with reduction compression ferrule

Gerade Einschraubverschraubung

mit Dichtkante

Union mâle

avec arête d'étanchéité

Male adaptor union

with edge seal

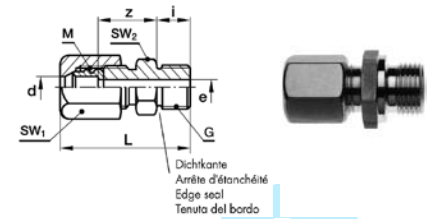

SO 51124

Type - d - G	Mat.-Nr.	bar	M	SW1	SW2	L	i	z	e	kg/100
Für metrische Rohre	Pour tubes métriques			For metric tubes						
G=Rohrgewinde (zylindrisch)	G=Filetage-gaz BSP (cylindrique)			G=BSP thread (straight)						
SO 51124-2-1/8	058.1141.020	250	6 x 0.75	8	14	23.0	8.0	12.0	2.2	2.130
SO 51124-3-1/8	058.1141.040	250	6 x 0.75	8	14	25.0	8.0	12.0	2.2	2.130
★ SO 51124-4-1/8	058.1141.060	200	10 x 1	12	14	30.5	8.0	14.5	4.5	2.170
★ SO 51124-4-1/4	058.1141.065	200	10 x 1	12	19	37.5	12.0	16.0	4.5	3.640
★ SO 51124-5-1/8	058.1141.082	200	10 x 1	12	14	30.5	8.0	14.5	4.5	2.130
★ SO 51124-5-1/4	058.1141.084	200	10 x 1	12	19	37.5	12.0	16.0	4.5	2.080
SO 51124-6-1/8	058.1141.100	200	10 x 1	12	14	30.5	8.0	14.5	4.5	2.080
SO 51124-6-1/4	058.1141.110	200	10 x 1	12	19	37.5	12.0	16.0	4.5	3.550
SO 51124-6-3/8	058.1141.120	200	10 x 1	12	22	37.0	12.0	17.5	4.5	3.550
SO 51124-6-1/2	058.1141.125	200	10 x 1	12	27	39.5	14.0	18.0	4.5	6.800
SO 51124-8-1/8	058.1141.160	200	12 x 1	14	14	32.0	8.0	15.5	5.0	3.800
SO 51124-8-1/4	058.1141.170	200	12 x 1	14	19	37.5	12.0	17.0	6.5	3.010
★ SO 51124-8-3/8	058.1141.180	160	14 x 1	17	22	41.5	12.0	18.5	8.5	6.220
SO 51124-8-1/2	058.1141.185	200	12 x 1	14	27	41.5	14.0	19.0	6.5	6.840
SO 51124-10-1/4	058.1141.270	160	14 x 1	17	19	40.0	12.0	17.0	8.5	4.560
SO 51124-10-3/8	058.1141.280	160	14 x 1	17	22	41.5	12.0	18.5	8.5	6.030
SO 51124-10-1/2	058.1141.285	160	14 x 1	17	27	44.0	14.0	19.0	8.5	8.820
SO 51124-10-3/4	058.1141.290	64	14 x 1	17	32	48.5	16.0	20.2	8.5	15.000
SO 51124-12-1/4	058.1141.380	160	16 x 1	19	19	41.0	12.0	17.0	7.0	5.300
SO 51124-12-3/8	058.1141.390	160	16 x 1	19	22	42.5	12.0	18.5	10.5	6.010
SO 51124-12-1/2	058.1141.400	160	16 x 1	19	27	45.0	14.0	19.0	10.5	7.600
SO 51124-12-3/4	058.1141.405	64	16 x 1	19	32	49.5	16.0	20.2	10.5	15.000
★ SO 51124-14-1/2	058.1141.504	100	20 x 1.5	24	27	49.5	14.0	21.5	13.0	10.660
SO 51124-15-1/2	058.1141.534	100	20 x 1.5	24	27	49.5	14.0	21.5	13.0	10.420
★ SO 51124-16-1/2	058.1141.566	100	24 x 1.5	27	27	51.0	14.0	21.5	13.5	12.850
SO 51124-18-1/2	058.1141.646	100	24 x 1.5	27	27	51.0	14.0	21.5	13.5	12.300
★ SO 51124-18-3/4	058.1141.648	64	28 x 1.5	32	32	57.5	16.0	22.5	19.0	19.750
SO 51124-18-1	058.1141.652	64	24 x 1.5	27	41	59.4	18.0	23.4	13.5	29.000
SO 51124-22-3/4	058.1141.768	64	28 x 1.5	32	32	57.5	16.0	22.5	19.0	18.350
SO 51124-28-1	058.1141.850	40	36 x 2	41	41	64.5	18.0	27.0	24.0	24.360
Für Zollrohre	Pour tubes pouces			For inch tubes						
SO 51124-3,2-1/8	058.1141.045	250	6 x 0.75	8	14	25.0	8.0	12.0	2.2	2.130
SO 51124-6,35-1/8	058.1141.135	200	10 x 1	12	14	30.5	8.0	14.5	4.5	2.060
SO 51124-6,35-1/4	058.1141.140	200	10 x 1	12	19	37.5	12.0	16.0	4.5	3.530
SO 51124-6,35-3/8	058.1141.145	200	10 x 1	12	22	37.0	12.0	17.5	4.5	3.530
★ SO 51124-6,35-1/2	058.1141.150	200	10 x 1	12	27	39.5	14.0	18.0	4.5	6.800
SO 51124-9,52-1/4	058.1141.230	160	14 x 1	17	19	40.0	12.0	17.0	8.5	4.590
SO 51124-9,52-3/8	058.1141.235	160	14 x 1	17	22	41.5	12.0	18.5	8.5	6.060
SO 51124-9,52-1/2	058.1141.240	160	14 x 1	17	27	44.0	14.0	19.0	8.5	8.850
SO 51124-12,7-1/2	058.1141.434	100	20 x 1.5	24	27	49.5	14.0	21.5	13.0	10.660
SO 51124-12,7-3/4	058.1141.536	64	20 x 1.5	24	32	53.5	16.0	22.2	13.0	17.000
★ SO 51124-13,5-1/2	058.1141.474	100	20 x 1.5	24	27	49.5	14.0	21.5	13.0	10.760
★ SO 51124-17,2-1/2	058.1141.616	100	24 x 1.5	27	27	51.0	14.0	21.5	13.5	12.550
★ SO 51124-21,3-3/4	058.1141.738	64	28 x 1.5	32	32	57.5	16.0	22.5	19.0	19.750

d=Rohrassen-ø
e=kleinste Bohrung
L=Mass in montiertem Zustand
*=mit reduziertem Klemmring

d=ø extérieur du tube
e=ø-min. de passage
L=après montage
*=avec bague de serrage de réduction

d=tube outside diameter
e=minimum bore
L=installed length
*=with reduction compression ferrule

Gerade Einschraubverschraubung METR

mit Dichtkante

Union mâl METRe

avec arête d'étanchéité

Male adaptor union METR

with edge seal

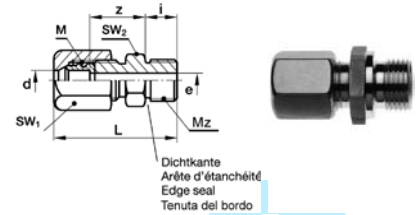
 Dichtkante
 Arête d'étanchéité
 Edge seal
 Tenuta del bordo

SO 51124 METR

Type -d -Mz	Mat.-Nr.	bar	M	SW1	SW2	L	i	z	e	kg/100	
Für metrische Rohre	Pour tubes métriques				For metric tubes						
Mz=metrisches Gewinde (zylindrisch)	Mz=Filetage métrique (cylindrique)				Mz=Metric thread (straight)						
SO 51124-2-M5	058.1143.020	250	6 x 0.75	8	8	17.5	4.5	10.0	2.2	0.500	
SO 51124-2-M6X0,75	058.1143.040	250	6 x 0.75	8	8	18.5	5.5	10.0	2.2	0.700	
SO 51124-3-M5	058.1143.050	250	6 x 0.75	8	8	19.5	4.5	10.0	2.2	0.540	
SO 51124-3-M6X0,75	058.1143.055	250	6 x 0.75	8	8	20.5	5.5	10.0	2.2	0.740	
* SO 51124-4-M5	058.1143.080	200	10 x 1	12	10	25.0	4.5	13.0	2.2	1.580	
* SO 51124-5-M5	058.1143.110	200	10 x 1	12	10	25.0	4.5	13.0	2.2	1.540	
SO 51124-6-M5	058.1143.155	200	10 x 1	12	10	25.0	4.5	13.0	2.2	1.490	
Für Zollrohre	Pour tubes pouces				For inch tubes						
SO 51124-6,35-M5	058.1143.205	200	10 x 1	12	10	25.0	4.5	13.0	2.2	1.470	

Gerade Einschraubverschraubung

mit O-Ringabdichtung (FPM)

Union mâle

avec joint torique (FPM)

Male adaptor union

with O-ring seal (FPM)

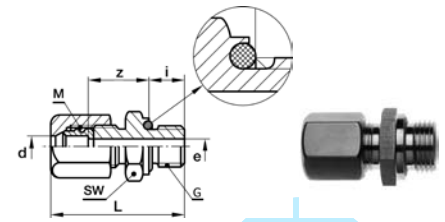

SO 51124 OR

Type - d - G	Mat.-Nr.	bar	M	SW	L	D	i	s	z	e	kg/100
Für metrische Rohre	Pour tubes métriques			For metric tubes							
G=Rohrgewinde (zylindrisch)	G=Filetage-gaz BSP (cylindrique)			G=BSP thread (straight)							
* SO 51124-4-1/8 OR	058.1171.060	200	10 x 1	14	30.0	15.0	8.0	1.00	14.5	4.5	2.200
* SO 51124-4-1/4 OR	058.1171.065	200	10 x 1	19	33.5	19.0	10.0	1.50	16.0	4.5	3.500
* SO 51124-5-1/8 OR	058.1171.082	200	10 x 1	14	30.0	15.0	8.0	1.00	14.5	4.5	2.100
* SO 51124-5-1/4 OR	058.1171.084	200	10 x 1	19	33.5	19.0	10.0	1.50	16.0	4.5	3.400
SO 51124-6-1/8 OR	058.1171.100	200	10 x 1	14	30.0	15.0	8.0	1.00	14.5	4.5	2.100
SO 51124-6-1/4 OR	058.1171.110	200	10 x 1	19	33.5	19.0	10.0	1.50	16.0	4.5	3.400
SO 51124-8-1/8 OR	058.1171.160	200	12 x 1	14	33.5	15.0	8.0	1.00	15.5	4.5	2.800
SO 51124-8-1/4 OR	058.1171.170	200	12 x 1	19	35.5	19.0	10.0	1.50	17.0	6.5	3.700
* SO 51124-8-3/8 OR	058.1171.180	160	14 x 1	22	39.5	23.0	10.0	2.00	18.5	8.5	6.100
SO 51124-10-1/4 OR	058.1171.270	160	14 x 1	19	38.0	19.0	10.0	1.50	17.0	7.0	4.400
SO 51124-10-3/8 OR	058.1171.280	160	14 x 1	22	39.5	23.0	10.0	2.00	18.5	8.5	5.900
* SO 51124-10-1/2 OR	058.1171.285	160	16 x 1	27	43.0	27.0	12.0	2.50	19.0	10.5	7.500
SO 51124-12-3/8 OR	058.1171.390	160	16 x 1	22	40.5	23.0	10.0	2.00	18.5	10.5	6.000
SO 51124-12-1/2 OR	058.1171.400	160	16 x 1	27	43.0	27.0	12.0	2.50	19.0	10.5	7.400
* SO 51124-14-1/2 OR	058.1171.504	100	20 x 1.5	27	47.5	27.0	12.0	2.50	21.5	13.0	10.400
SO 51124-15-1/2 OR	058.1171.534	100	20 x 1.5	27	47.5	27.0	12.0	2.50	21.5	13.0	10.200
* SO 51124-16-1/2 OR	058.1171.566	100	24 x 1.5	27	49.0	27.0	12.0	2.50	21.5	13.0	12.500
SO 51124-18-1/2 OR	058.1171.646	100	24 x 1.5	27	49.0	27.0	12.0	2.50	21.5	13.0	12.000
* SO 51124-18-3/4 OR	058.1171.648	64	28 x 1.5	32	53.5	33.0	12.0	2.50	22.5	19.0	19.400
SO 51124-22-3/4 OR	058.1171.768	64	28 x 1.5	32	53.5	33.0	12.0	2.50	22.5	19.0	18.000
Für Zollrohre	Pour tubes pouces			For inch tubes							
SO 51124-6,35-1/8 OR	058.1171.135	200	10 x 1	14	30.0	15.0	8.0	1.00	14.5	4.5	2.000
SO 51124-6,35-1/4 OR	058.1171.140	200	10 x 1	19	33.5	19.0	10.0	1.50	16.0	4.5	3.300
SO 51124-9,52-1/4 OR	058.1171.230	160	14 x 1	19	38.0	19.0	10.0	1.50	17.0	7.0	4.500
SO 51124-9,52-3/8 OR	058.1171.235	160	14 x 1	22	39.5	23.0	10.0	2.00	18.5	8.5	5.800
SO 51124-12,7-1/2 OR	058.1171.434	100	20 x 1.5	27	47.5	27.0	12.0	2.50	21.5	13.0	10.800
* SO 51124-13,5-1/2 OR	058.1171.474	100	20 x 1.5	27	47.5	27.0	12.0	2.50	21.5	13.0	10.500
* SO 51124-17,2-1/2 OR	058.1171.616	100	24 x 1.5	27	49.0	27.0	12.0	2.50	21.5	13.0	12.200
* SO 51124-21,3-3/4 OR	058.1171.738	64	28 x 1.5	32	53.5	33.0	12.0	2.50	22.5	19.0	19.000

Anwendungsbeispiele:

Exemples d'utilisation:

Sample combinations:

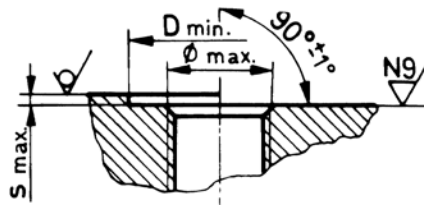

Temperatur max. +200°C
conovor® patentierte O-Ring Abdichtung

Température max. +200°C
conovor® breveté joint torique étanchéité

Temperature max. +200°C
conovor® patented O-ring sealing

d=Rohrassen-ø
e=kleinste Bohrung
L=Mass in montiertem Zustand
*=mit reduziertem Klemmring

d=ø extérieur du tube
e=ø-min. de passage
L=après montage
*=avec bague de serrage de réduction

d=tube outside diameter
e=minimum bore
L=installed length
*=with reduction compression ferrule

Durchgangsschraubung (Thermofühlerverschraubung)

mit Klemmring aus Edelstahl

Raccordement pour sondes

avec bague de serrage en acier inoxydable

Temperature probe union

with stainless steel compression ferrule

SO 51124-D

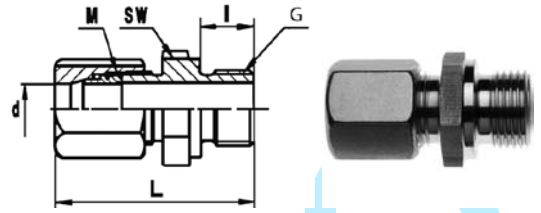

Type -d-G	Mat.-Nr.	M	SW	i	L
G=Rohrgewinde (zylindrisch)	G=Filetage-gaz BSP (cylindrique)			G=BSP thread (straight)	
SO 51124-2-1/8-D	058.1151.020	6x0.75	14	8.0	23.0
SO 51124-3-1/8-D	058.1151.040	6x0.75	14	8.0	25.0
SO 51124-3-1/4-D	058.1151.042	6x0.75	19	12.0	31.5
SO 51124-3-1/2-D	058.1151.044	6x0.75	27	14.0	36.5
SO 51124-4-1/8-D	058.1151.060	8x1	14	8.0	28.5
SO 51124-4-1/4-D	058.1151.065	8x1	19	12.0	32.0
SO 51124-5-1/8-D	058.1151.082	8x1	14	8.0	29.0
SO 51124-5-1/4-D	058.1151.084	8x1	19	12.0	32.5
SO 51124-6-1/8-D	058.1151.100	10x1	14	8.0	30.0
SO 51124-6-1/4-D	058.1151.110	10x1	19	12.0	35.5
SO 51124-6-1/2-D	058.1151.125	10x1	27	14.0	42.5
SO 51124-8-1/4-D	058.1151.170	12x1	19	12.0	37.0
SO 51124-10-3/8-D	058.1151.280	14x1	22	12.0	40.5
SO 51124-10-1/2-D	058.1151.285	14x1	27	14.0	46.0
SO 51124-12-3/8-D	058.1151.390	16x1	22	12.0	41.5
SO 51124-15-1/2-D	058.1151.534	20x1.5	27	14.0	49.0

Durchgangsschraubung METR (Thermofühlerverschraubung)

mit Klemmring aus Edels

Raccordement pour sondes METR

avec bague de serrage en acier inoxydable

Temperature probe union METR

with stainless steel compression ferrule

SO 51124-D METR

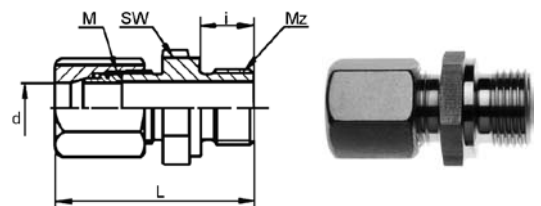

Type -d-Mz	Mat.-Nr.	M	SW	i	L
Mz=metrisches Gewinde (zylindrisch)	Mz=Filetage métrique (cylindrique)			Mz=Metric thread (straight)	
SO 51124-1-M8X1-D	058.1153.006	6x0.75	12	8.0	23.0
SO 51124-1,5-M8X1-D	058.1153.011	6x0.75	12	8.0	23.0
SO 51124-1,5-M10X1-D	058.1153.012	6x0.75	14	8.0	24.0
SO 51124-2-M8X1-D	058.1153.035	6x0.75	12	8.0	24.0
SO 51124-2,5-M8X1-D	058.1153.043	6x0.75	12	8.0	25.0
SO 51124-3-M8X1-D	058.1153.060	6x0.75	12	8.0	25.0
SO 51124-3-M10X1-D	058.1153.065	6x0.75	14	8.0	26.0
SO 51124-3,5-M8X1-D	058.1153.068	8x1	12	8.0	28.0
SO 51124-4-M10X1-D	058.1153.096	8x1	14	8.0	28.0
SO 51124-5-M10X1-D	058.1153.135	10x1	14	8.0	29.0
SO 51124-6-M10X1-D	058.1153.180	10x1	14	8.0	30.0

d=Rohrøussen-ø

L= Mass in montiertem Zustand

*=mit reduziertem Klemmring

d=ø extérieur du tube

L=après montage

*=avec bague de serrage de réduction

d=tube outside diameter

L=installed length

*=with reduction compression ferrule

Anwendungsbeispiele:

Exemples d'utilisation:

Sample combinations:

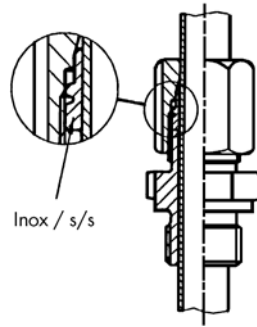

Temperatur/Druck bis +300° C und 6 bar

Der Klemmring presst bei der ersten Montage – durch Anziehen der Mutter – auf das Rohr bleibend auf, es entsteht eine metallische Dichtung.

Die Verbindung kann durch Lösen der Mutter demontiert werden, wobei allerdings der Klemmring auf dem Rohr haften bleibt. Es ist also nach der Erstmontage kein Verschieben des Rohres möglich.

Das Verschieben wird durch den Einsatz von Durchgangverschraubungen mit Teflonklemmring SO 51 194-D-PTFE erzielt.

Température/Pression jusqu'au +300° C et 6 bar

Au premier serrage du raccord la bague de serrage étrangle légèrement le tube. Le résultat est une étanchéité métal sur métal.

Par desserrage de l'écrou le raccordement peut être démonté. La bague de serrage reste sur le tube.

Un déplacement du tube n'est pas possible après le premier montage.

Le déplacement peut être effectué par l'utilisation des unions doubles avec une bague de serrage en téflon SO 51 194-D-PTFE.

Temperature/Pressure up to +300° C and 6 bar

When mounted for the first time, the compression ferrule is pressed onto the tube by tightening the nut. A metal sealing is the result.

The union can be demounted by loosening the nut. However, the compression ferrule remains on the tube.

A displacement of the tube is not possible after the first mounting.

The displacement is achieved by using straight unions with a teflon compression ferrule SO 51 194-D-PTFE.

KONVEX

d=Rohraussen-ø
L= Mass in montiertem Zustand
*=mit reduziertem Klemmring

d=ø extérieur du tube
L=après montage
*=avec bague de serrage de réduction

d=tube outside diameter
L=installed length
*=with reduction compression ferrule

Durchgangsverschraubung (Thermofühlerverschraubung)

mit PTFE-Klemmring

Raccordement pour sondes

avec bague de serrage en PTFE

Temperature probe union

with PTFE compression ferrule

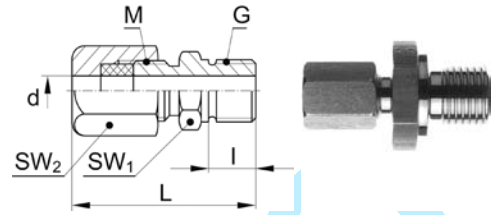

SO 51194-D-PTFE

Typ -d-G	Mat.-Nr.	M	SW1	SW2	L	l1	kg/100
G=Rohrgewinde (zylindrisch)		G=Filetage-gaz BSP (cylindrique)		G=BSP thread (straight)			
SO 51194-1-1/4	058.1165.002	6 x 0.75	19	8	30.0	12.0	2.640
SO 51194-1-1/2	058.1165.004	6 x 0.75	27	8	33.0	12.0	6.320
SO 51194-1,5-1/4	058.1165.011	6 x 0.75	19	8	30.0	12.0	2.640
SO 51194-1,5-1/2	058.1165.013	6 x 0.75	27	8	33.0	12.0	6.340
SO 51194-2-1/8	058.1165.020	6 x 0.75	14	8	24.0	8.0	1.260
SO 51194-2-1/4	058.1165.021	6 x 0.75	19	8	30.0	12.0	2.630
SO 51194-2-1/2	058.1165.023	6 x 0.75	27	8	33.0	12.0	6.310
SO 51194-2.5-1/8	058.1165.030	6 x 0.75	14	8	24.0	8.0	1.250
SO 51194-2.5-1/4	058.1165.031	6 x 0.75	19	8	30.0	12.0	2.620
SO 51194-2.5-1/2	058.1165.033	6 x 0.75	27	8	33.0	12.0	6.290
SO 51194-3-1/8	058.1165.040	6 x 0.75	14	8	24.0	8.0	1.370
SO 51194-3-1/4	058.1165.042	6 x 0.75	19	8	30.0	12.0	1.250
SO 51194-3-1/2	058.1165.044	6 x 0.75	27	8	33.0	12.0	2.610
SO 51194-3.5-1/8	058.1165.047	8 x 1	14	10	30.0	8.0	6.280
SO 51194-3.5-1/4	058.1165.049	8 x 1	19	10	35.0	12.0	1.250
SO 51194-4-1/8	058.1165.060	8 x 1	14	10	30.0	8.0	1.680
SO 51194-4-1/4	058.1165.065	8 x 1	19	10	35.0	12.0	2.880
SO 51194-4-1/2	058.1165.070	8 x 1	27	10	38.0	12.0	6.680
SO 51194-4.5-1/8	058.1165.076	8 x 1	14	10	30.0	8.0	1.680
SO 51194-4.5-1/4	058.1165.077	8 x 1	19	10	36.0	12.0	2.940
SO 51194-5-1/8	058.1165.082	10 x 1	14	12	31.0	8.0	1.990
SO 51194-5-1/4	058.1165.084	10 x 1	19	12	36.0	12.0	3.220
SO 51194-5-1/2	058.1165.088	10 x 1	27	12	39.0	12.0	7.030
SO 51194-5-3/4	058.1165.089	10 x 1	32	12	44.0	16.0	14.190
SO 51194-6-1/4	058.1165.110	10 x 1	19	12	36.0	12.0	2.790
SO 51194-6-1/2	058.1165.125	10 x 1	27	12	39.0	12.0	6.880
SO 51194-6-3/4	058.1165.126	10 x 1	32	12	44.0	16.0	13.900
SO 51194-8-1/4	058.1165.170	14 x 1	19	17	38.0	12.0	4.080
SO 51194-8-3/8	058.1165.180	14 x 1	22	17	39.0	12.0	5.310
SO 51194-8-1/2	058.1165.185	14 x 1	27	17	39.0	12.0	7.010
SO 51194-8-3/4	058.1165.190	14 x 1	32	17	44.0	16.0	10.790
SO 51194-9-1/2	058.1165.210	14 x 1	27	17	39.0	12.0	6.830
SO 51194-9-3/4	058.1165.214	14 x 1	32	17	44.0	16.0	10.610
SO 51194-10-3/8	058.1165.280	14 x 1	22	17	39.0	12.0	5.030
SO 51194-10-1/2	058.1165.285	14 x 1	27	17	39.0	12.0	6.610
SO 51194-10-3/4	058.1165.290	14 x 1	32	17	44.0	16.0	10.340

Werkstoff: 1.4571 Klemmring aus PTFE
**Temperatur/Druck bis +250 °C und
 6 bar**

Matériau: 1.4571 bague de serrage en PTFE
**Température/Pression jusqu'au
 +250 °C et 6 bar.**

Material: 1.4571 compression ferrule of PTFE
**Temperature/Pressure up to +250 °C
 and 6 bar.**

Durchgangsschraubung METR (Thermofühlerverschraubung)

mit PTFE-Klemmring

Raccordement pour sondes METR

avec bague de serrage en PTFE

Temperature probe union METR

with PTFE compression ferrule

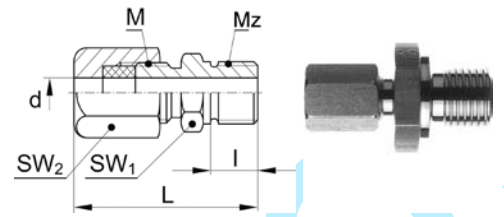

SO 51194-D-PTFE METR

Type -d -Mz	Mat.-Nr.	M	SW1	SW2	L	l1	kg/100
Mz=metrisches Gewinde (zylindrisch)		Mz=Filetage métrique (cylindrique)				Mz=Metric thread (straight)	
SO 51194-0,5-M8x1	058.1167.003	6 x 0.75	12	8	24.0	8.0	1.400
SO 51194-1-M8x1	058.1167.006	6 x 0.75	12	8	24.0	8.0	1.400
SO 51194-1-M10x1	058.1167.004	6 x 0.75	14	8	24.0	8.0	1.280
SO 51194-1,5-M8x1	058.1167.011	6 x 0.75	12	8	24.0	8.0	1.020
SO 51194-1,5-M10x1	058.1167.012	6 x 0.75	14	8	24.0	8.0	1.270
SO 51194-2-M8x1	058.1167.035	6 x 0.75	12	8	24.0	8.0	1.000
SO 51194-2-M10x1	058.1167.036	6 x 0.75	14	8	24.0	8.0	1.260
SO 51194-2.5-M8x1	058.1167.043	6 x 0.75	12	8	24.0	8.0	1.000
SO 51194-2.5-M10x1	058.1167.044	6 x 0.75	14	8	24.0	8.0	1.240
SO 51194-3-M8x1	058.1167.060	6 x 0.75	12	8	24.0	8.0	0.980
SO 51194-3-M10x1	058.1167.065	6 x 0.75	14	8	24.0	8.0	1.250
SO 51194-3.5-M8x1	058.1167.075	8 x 1	12	10	30.0	8.0	1.380
SO 51194-4-M8x1	058.1167.090	8 x 1	12	10	30.0	8.0	1.330
SO 51194-4-M10x1	058.1167.096	8 x 1	14	10	30.0	8.0	1.068
SO 51194-5-M10x1	058.1167.135	10 x 1	14	12	31.0	8.0	1.980
SO 51194-6-M10x1	058.1167.180	10 x 1	14	12	31.0	8.0	1.790

Werkstoff: 1.4571 Klemmring aus PTFE

**Temperatur/Druck bis +250 °C
und 6 bar**

Matériau: 1.4571 bague de serrage en PTFE

**Température/Pression jusqu'au
+250 ° C et 6 bar**

Material: 1.4571 compression ferrule of PTFE

**Temperature/Pressure up to
+250 ° C and 6 bar**

PTFE Klemmring zu SO 51194

Bague de serrage en PTFE pour SO 51194

PTFE compression ferrule for SO 51194

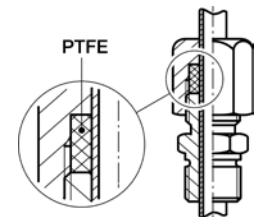

SO 50009

Type -d	Mat.-Nr.
SO 50009-1	056.0016.510
SO 50009-1,5	056.0016.515
SO 50009-2	056.0016.520
SO 50009-2,5	056.0016.525
SO 50009-3	056.0016.530
SO 50009-4	056.0016.540
SO 50009-5	056.0016.550
SO 50009-6	056.0016.560
SO 50009-8	056.0016.580
SO 50009-9	056.0016.590
SO 50009-10	056.0016.600

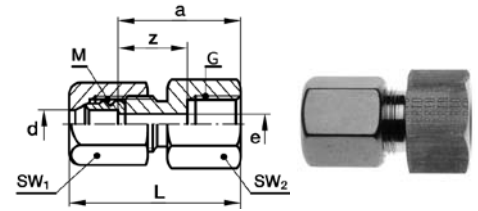
Gerade Aufschraubverschraubung
Union femelle
Female adaptor union

SO 51221

Type -d-G	Mat.-Nr.	bar	M	SW1	SW2	L	a	z	e	kg/100
Für metrische Rohre	Pour tubes métriques			For metric tubes						
G=Rohrgewinde (zylindrisch)	G=Filetage-gaz BSP (cylindrique)			G=BSP thread (straight)						
* SO 51221-3-1/8	058.1201.040	250	8 x 1	10	14	27.0	22.0	12.0	3.5	1.810
SO 51221-4-1/8	058.1201.060	250	8 x 1	10	14	27.0	22.0	12.0	3.5	1.830
* SO 51221-4-1/4	058.1201.065	200	10 x 1	12	17	31.5	24.0	13.0	4.5	3.020
SO 51221-5-1/8	058.1201.082	250	8 x 1	10	14	27.0	22.0	12.0	3.5	1.810
* SO 51221-5-1/4	058.1201.084	200	10 x 1	12	17	31.5	24.0	13.0	4.5	2.980
SO 51221-6-1/8	058.1201.100	200	10 x 1	12	14	29.5	22.0	12.0	4.5	2.220
SO 51221-6-1/4	058.1201.110	200	10 x 1	12	17	31.5	24.0	13.0	4.5	2.930
SO 51221-6-3/8	058.1201.120	200	10 x 1	12	22	32.5	25.0	13.0	4.5	4.370
SO 51221-6-1/2	058.1201.125	200	10 x 1	12	27	38.5	31.0	17.0	4.5	8.170
SO 51221-8-1/4	058.1201.170	200	12 x 1	14	17	33.5	25.0	14.0	6.5	3.150
* SO 51221-8-3/8	058.1201.180	160	14 x 1	17	22	37.0	26.0	14.0	8.5	5.460
* SO 51221-8-1/2	058.1201.185	160	14 x 1	17	27	39.0	28.0	14.0	8.5	7.570
SO 51221-10-1/4	058.1201.270	160	14 x 1	17	17	36.0	25.0	14.0	8.5	4.120
SO 51221-10-3/8	058.1201.280	160	14 x 1	17	22	37.0	26.0	14.0	8.5	5.460
SO 51221-10-1/2	058.1201.285	160	14 x 1	17	27	39.0	28.0	14.0	8.5	7.570
SO 51221-12-1/4	058.1201.380	160	16 x 1	19	17	37.0	25.0	14.0	10.5	4.520
SO 51221-12-3/8	058.1201.390	160	16 x 1	19	22	38.0	26.0	14.0	10.5	5.890
SO 51221-12-1/2	058.1201.400	160	16 x 1	19	27	40.0	28.0	14.0	10.5	7.820
* SO 51221-14-1/2	058.1201.504	100	20 x 1.5	24	27	44.5	30.5	16.5	13.0	10.340
SO 51221-15-1/2	058.1201.534	100	20 x 1.5	24	27	44.5	30.5	16.5	13.0	10.100
* SO 51221-16-1/2	058.1201.566	100	24 x 1.5	27	27	46.0	30.5	16.5	15.0	12.240
SO 51221-18-1/2	058.1201.646	100	24 x 1.5	27	27	46.0	30.5	16.5	15.0	11.720
Für Zollrohre	Pour tubes pouces			For inch tubes						
SO 51221-6,35-1/8	058.1201.135	200	10 x 1	12	14	29.5	22.0	12.0	4.5	2.200
SO 51221-6,35-1/4	058.1201.140	200	10 x 1	12	17	31.5	24.0	13.0	4.5	2.910
SO 51221-6,35-3/8	058.1201.145	200	10 x 1	12	22	32.5	25.0	13.0	4.5	4.350
SO 51221-6,35-1/2	058.1201.150	200	10 x 1	12	27	38.5	31.0	17.0	4.5	8.180
SO 51221-9,52-1/4	058.1201.230	160	14 x 1	17	17	36.0	25.0	14.0	8.5	4.150
SO 51221-9,52-3/8	058.1201.235	160	14 x 1	17	22	37.0	26.0	14.0	8.5	5.490
SO 51221-9,52-1/2	058.1201.240	160	14 x 1	17	27	39.0	28.0	14.0	8.5	7.600
SO 51221-12,7-1/2	058.1201.434	100	20 x 1.5	24	27	44.5	30.5	16.5	13.0	10.540
* SO 51221-13,5-1/2	058.1201.474	100	20 x 1.5	24	27	44.5	30.5	16.5	13.0	10.440
* SO 51221-17,2-1/2	058.1201.616	100	24 x 1.5	27	27	46.0	30.5	16.5	15.0	11.970

d=Rohraussen-ø
e=kleinste Bohrung
L=Mass in montiertem Zustand
*=mit reduziertem Klemmring

d=ø extérieur du tube
e=ø-min. de passage
L=après montage
*=avec bague de serrage de réduction

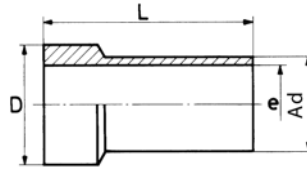
d=tube outside diameter
e=minimum bore
L=installed length
*=with reduction compression ferrule

Verbindungsniessel
Pièce folle
Tube stub
SO 51300

Type -Ad	Mat.-Nr.	bar	L	D	e	kg/100
SO 51300-A6	056.1300.060	200	19.0	8.5	4.0	0.320
SO 51300-A8	056.1300.080	200	22.0	10.5	6.0	0.480
SO 51300-A10	056.1300.100	160	26.0	12.7	7.5	0.870
SO 51300-A12	056.1300.120	160	29.0	14.7	9.0	1.290
SO 51300-A15	056.1300.150	100	35.0	18.0	12.0	2.100
SO 51300-A18	056.1300.180	100	39.0	22.0	15.0	3.100
SO 51300-A22	056.1300.220	64	43.0	26.0	19.0	4.200

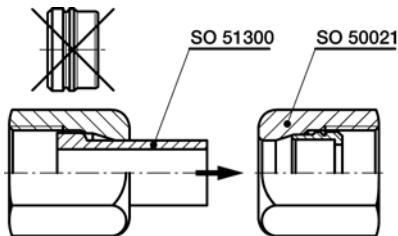
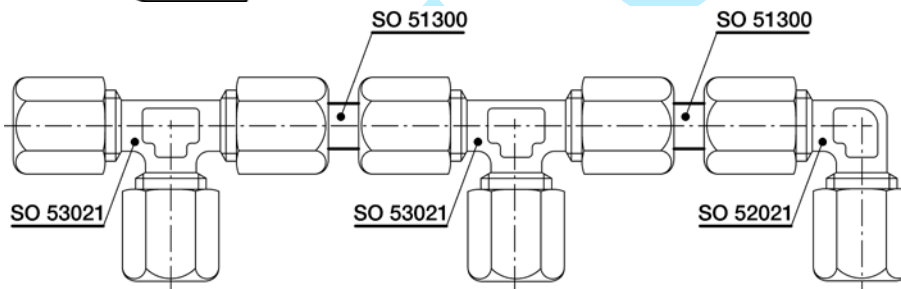
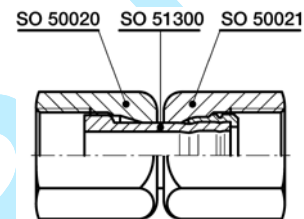
Anwendungsbeispiele:

Exemples d'utilisation:

Sample combinations:

Der Verbindungsniessel SO 51300 / SO 51304 montiert mit Anschlussmutter SO 50020 d und Armaturenanschluss SO 50021 -d ergibt eine einstellbare Kupplung. Mit der einstellbaren Kupplung lassen sich alle Formteile mit dem gleichen Anschlussgewinde M verbinden. Weitere einstellbare Verschraubungen siehe SO 51600, SO 52621, SO 53621.

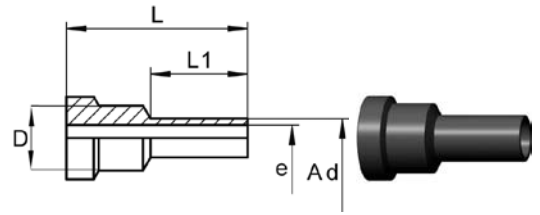
La pièce folle SO 51300 / SO 51304 montée avec les écrous SO 50020 d et SO 50021 -d donne une union orientable. L'union orientable permet l'assemblage de tous les raccords orientables, voir SO 51600, SO 52621, SO 53621.

The tube stub SO 51300 / SO 51304 assembled together with the union nut SO 50020 d and the nut connection SO 50021 -d provides an adjustable coupling. The adjustable coupling permits the connection of all fittings with the same connector thread M. See SO 51600, SO 52621, SO 53621 for other adjustable unions.

Verbindungsrippel reduziert
Pièce folle réduite
Reducing port connector

SO 51300 RED

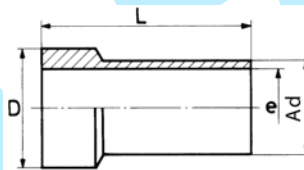
Type -Ad	Mat.-Nr.	bar	L	L1	D	e	kg/100
SO 51300-8-A6 RED	056.1304.140	200	26.0	14.0	10.5	4.0	0.650
SO 51300-10-A6 RED	056.1304.175	200	28.0	15.0	12.7	4.0	1.000
SO 51300-10-A8 RED	056.1304.190	200	28.0	16.0	12.7	6.0	0.910
SO 51300-12-A6 RED	056.1304.215	200	29.0	15.0	14.7	4.0	1.420
SO 51300-12-A8 RED	056.1304.225	200	29.0	15.0	14.7	6.0	1.350
SO 51300-12-A10 RED	056.1304.240	160	31.0	18.0	14.7	8.0	1.420
SO 51300-15-A10 RED	056.1304.410	160	35.0	19.0	18.0	8.0	2.270
SO 51300-15-A12 RED	056.1304.420	160	35.0	20.0	18.0	10.0	2.000
SO 51300-18(16)-A12 RED	056.1304.480	160	35.0	20.0	22.0	9.0	3.040
SO 51300-18(16)-A16 RED	056.1304.620	100	41.0	34.5	22.0	13.0	2.960

Verbindungsrippel
Pièce folle
Tube stub

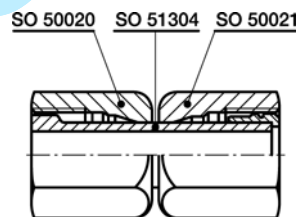
SO 51304

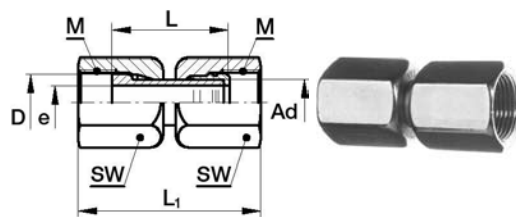
Type -Ad	Mat.-Nr.	bar	L	D	e	kg/100
radial demontierbar	démontable radialement			radial dismantling		
SO 51304-A6	056.1310.060	200	29.0	8.5	4.0	0.440
SO 51304-A8	056.1310.080	200	32.0	10.5	6.0	0.670
SO 51304-A10	056.1310.100	160	37.0	12.7	7.5	1.170
SO 51304-A12	056.1310.120	160	39.0	14.7	9.0	1.720

Anwendungsbeispiele:
Exemples d'utilisation:
Sample combinations:

Einstellbare Kupplung
Pièce folle montée
Tube stub assembly

SO 51325

Type -Ad	Mat.-Nr.	bar	M	SW	L	L1	D	e	kg/100
SO 51325-A6	058.1320.060	200	10 x 1	12	20.0	32.0	8.5	4.0	1.900
SO 51325-A8	058.1320.080	200	12 x 1	14	23.0	36.0	10.5	6.0	2.580
SO 51325-A10	058.1320.100	160	14 x 1	17	27.0	40.0	12.7	7.5	4.430
SO 51325-A12	058.1320.120	160	16 x 1	19	30.0	43.0	14.7	9.0	5.710
SO 51325-A15	058.1320.150	100	20 x 1.5	24	36.5	52.0	18.0	12.0	10.520
SO 51325-A18	058.1320.180	100	24 x 1.5	27	40.5	55.0	22.0	15.0	13.200
SO 51325-A22	058.1320.220	64	28 x 1.5	32	44.5	58.0	26.0	19.0	20.520

radial demontierbar

démontable radialement

radial dismantling

SO 51326-A6	058.1330.060	200	10 x 1	12	30.2	42.0	8.5	4.0	2.020
SO 51326-A8	058.1330.080	200	12 x 1	14	33.2	46.0	10.5	6.0	2.770
SO 51326-A10	058.1330.100	160	14 x 1	17	38.2	51.0	12.7	7.5	4.730
SO 51326-A12	058.1330.120	160	16 x 1	19	40.2	53.0	14.7	9.0	6.140

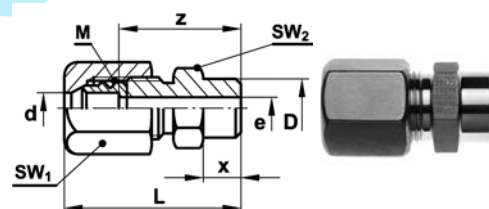
Anschweissverschraubung
Union avec embout à souder
Weld-on union

SO 51429

Type -d	Mat.-Nr.	bar	M	SW1	SW2	L	D	x	z	e	kg/100
Für metrische Rohre	Pour tubes métriques		For metric tubes								
★ SO 51429-3	058.1400.030	250	8 x 1	10	8	25.0	7.5	6.0	19.0	3.5	1.050
SO 51429-4	058.1400.040	250	8 x 1	10	8	25.0	7.5	6.0	19.0	3.5	1.020
SO 51429-5	058.1400.050	250	8 x 1	10	8	25.0	7.5	6.0	19.0	3.5	1.000
SO 51429-6	058.1400.060	200	10 x 1	12	10	28.5	9.8	8.0	21.0	4.5	1.690
SO 51429-8	058.1400.080	200	12 x 1	14	12	30.5	11.8	8.0	22.0	6.5	2.250
SO 51429-10	058.1400.100	160	14 x 1	17	14	34.0	13.8	8.0	23.0	8.5	3.380
SO 51429-12	058.1400.120	160	16 x 1	19	17	36.0	16.0	8.0	24.0	10.5	4.340
★ SO 51429-14	058.1400.140	100	20 x 1.5	24	22	43.5	19.0	10.0	29.5	13.0	8.240
SO 51429-15	058.1400.150	100	20 x 1.5	24	22	43.5	19.0	10.0	29.5	13.0	8.000
★ SO 51429-16	058.1400.160	100	24 x 1.5	27	24	47.0	22.0	11.0	31.5	15.0	11.760
SO 51429-18	058.1400.180	100	24 x 1.5	27	24	47.0	22.0	11.0	31.5	15.0	11.210
SO 51429-22	058.1400.220	64	28 x 1.5	32	30	51.5	27.0	11.0	32.5	19.0	17.000
SO 51429-28	058.1400.280	40	36 x 2	41	36	59.5	32.0	14.0	40.0	24.0	22.500

Für Zollrohre

Pour tubes pouces

For inch tubes

SO 51429-6,35	058.1400.063	200	10 x 1	12	10	28.5	9.8	8.0	21.0	4.5	1.670
SO 51429-9,52	058.1400.095	160	14 x 1	17	14	34.0	13.8	8.0	23.0	8.5	3.410
SO 51429-12,7	058.1400.127	100	20 x 1.5	24	22	43.5	19.0	10.0	29.5	13.0	8.440
★ SO 51429-13,5	058.1400.135	100	20 x 1.5	24	22	43.5	19.0	10.0	29.5	13.0	8.340
★ SO 51429-17,2	058.1400.172	100	24 x 1.5	27	24	47.0	22.0	11.0	31.5	15.0	11.460
★ SO 51429-21,3	058.1400.213	64	28 x 1.5	32	30	51.5	27.0	11.0	32.5	19.0	18.400

d=Rohrassen-ø
 e=kleinste Bohrung
 L=Mass in montiertem Zustand
 *=mit reduziertem Klemmring

d=ø extérieur du tube
 e=ø-min. de passage
 L=après montage
 *=with reduction compression ferrule

d=tube outside diameter
 e=minimum bore
 L= installed length
 *=with reduction compression ferrule

Gerade Schottverschraubung

Durchführungslänge max. 5 mm

Union double pour passage de cloison

pour cloison max. 5 mm

Panel mount union

max. panel thickness 5 mm

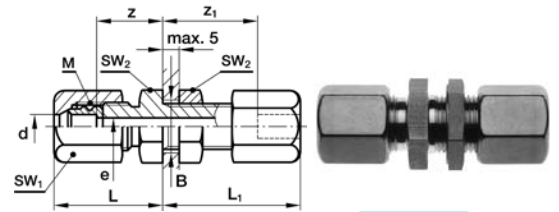

SO 51521

Type-d	Mat.-Nr.	bar	M	SW1	SW2	L	L1	B	z1	z	e	kg/100
Für metrische Rohre	Pour tubes métriques			For metric tubes								
SO 51521-2	058.1500.020	250	6x0.75	8	10	13.5	18.5	6.5	15.5	10.5	2.2	1.190
SO 51521-3	058.1500.030	250	6x0.75	8	10	15.5	20.5	6.5	15.5	10.5	2.2	1.270
SO 51521-4	058.1500.040	250	8x1	10	12	19.0	23.0	8.5	17.5	13.5	3.5	2.240
SO 51521-5	058.1500.050	250	8x1	10	12	19.5	23.5	8.5	17.5	13.5	3.5	2.200
SO 51521-6	058.1500.060	200	10x1	12	14	21.0	26.5	10.5	19.0	13.5	4.5	3.610
SO 51521-8	058.1500.080	200	12x1	14	17	23.5	29.5	12.5	21.0	15.0	6.5	5.210
SO 51521-10	058.1500.100	160	14x1	17	19	26.5	32.0	14.5	21.0	15.5	8.5	7.330
SO 51521-12	058.1500.120	160	16x1	19	22	28.0	33.0	16.5	21.0	16.0	10.5	9.400
Für Zollrohre	Pour tubes pouces			For inch tubes								
SO 51521-6,35	058.1500.063	200	10x1	12	14	21.0	26.5	10.5	19.0	13.5	4.5	3.570
SO 51521-9,52	058.1500.095	160	14x1	17	19	26.5	32.0	14.5	21.0	15.5	8.5	7.390

Gerade Schottverschraubung reduziert

Durchführungslänge max. 5 mm

Union double réduite pour passage de cloison

pour cloison max. 5 mm

Panel mount reduction union

max. panel thickness 5 mm

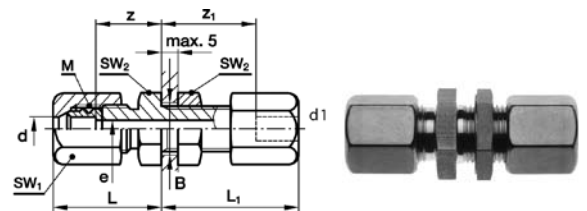

SO 51521 RED

Type-d-d1	Mat.-Nr.	bar	M	SW1	SW2	L	L1	z1	z	e	kg/100	
Für metrische Rohre	Pour tubes métriques			For metric tubes								
SO 51521-3-2	058.1504.020	250	6x0.75	8	10	15.5	18.5	15.5	10.5	2.2	1.190	
* SO 51521-5-3	058.1504.060	250	8x1	10	12	19.5	23.5	17.5	13.5	3.5	2.290	
* SO 51521-5-4	058.1504.080	200	10x1	12	14	21.5	27.0	19.0	13.5	4.5	2.300	
* SO 51521-6-4	058.1504.110	200	10x1	12	14	21.5	27.0	19.0	13.5	4.5	3.720	
* SO 51521-6-5	058.1504.117	200	10x1	12	14	21.5	27.0	19.0	13.5	4.5	3.700	
* SO 51521-8-6	058.1504.140	200	12x1	14	17	23.5	29.5	21.0	15.0	6.5	5.370	
* SO 51521-10-4	058.1504.167	160	14x1/10x1	17	14	25.5	27.0	19.0	14.5	4.5	5.800	
* SO 51521-10-5	058.1504.170	160	14x1/10x1	17	14	25.5	27.0	19.0	14.5	4.5	5.750	
SO 51521-10-6	058.1504.175	160	14x1/10x1	17	14	25.5	27.0	19.0	14.5	4.5	5.700	
* SO 51521-10-8	058.1504.190	160	14x1	17	19	26.5	32.0	21.0	15.5	8.5	7.520	
* SO 51521-12-10	058.1504.240	160	16x1	19	22	28.0	33.0	21.0	16.0	10.5	9.600	
Für Zollrohre	Pour tubes pouces			For inch tubes								
SO 51521-6-6,35	058.1504.119	200	10x1	12	14	21.5	27.0	19.0	13.5	4.5	3.610	
* SO 51521-8-6,35	058.1504.143	200	12x1	14	17	23.5	29.5	21.0	15.0	6.5	5.350	
SO 51521-10-9,52	058.1504.197	160	14x1	17	19	26.5	32.0	21.0	15.5	8.5	7.330	

d=Rohrassen-ø
e= kleinste Bohrung
L= Mass in montiertem Zustand
*=mit reduziertem Klemmring

d=ø extérieur du tube
e= ø-min. de passage
L=après montage
*=avec bague de serrage de réduction

d=tube outside diameter
e=minimum bore
L=installed length
*=with reduction compression ferrule

Gerade Schottverschraubung

Durchführungslänge max. 16mm

Union double pour passage de cloison

pour cloison max. 16mm

Panel mount union

max. panel thickness 16mm

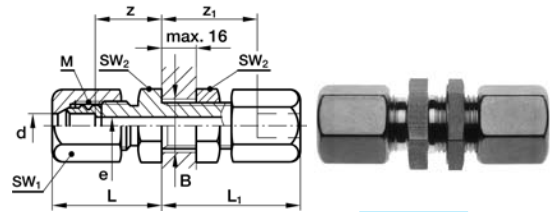

SO 51524

Type-d	Mat.-Nr.	bar	M	SW1	SW2	L1	L2	B	z1	z	e	kg/100
Für metrische Rohre	Pour tubes métriques			For metric tubes								
* SO 51524-14	058.1540.140	100	20 x 1.5	24	27	33.5	47.5	20.5	33.5	19.5	13.0	18.010
SO 51524-15	058.1540.150	100	20 x 1.5	24	27	33.5	47.5	20.5	33.5	19.5	13.0	17.680
* SO 51524-16	058.1540.160	100	24 x 1.5	27	30	35.0	50.0	24.5	34.5	19.5	15.0	24.650
SO 51524-18	058.1540.180	100	24 x 1.5	27	30	35.0	50.0	24.5	34.5	19.5	15.0	25.300
SO 51524-22	058.1540.220	64	28 x 1.5	32	36	39.5	54.5	28.5	35.5	20.5	19.0	33.490

Für Zollrohre	Pour tubes pouces	For inch tubes										
SO 51524-12,7	058.1540.127	100	20 x 1.5	24	27	33.5	47.5	20.5	33.5	19.5	13.0	18.410
* SO 51524-13,5	058.1540.135	100	20 x 1.5	24	27	33.5	47.5	20.5	33.5	19.5	13.0	18.210
* SO 51524-17,2	058.1540.172	100	24 x 1.5	27	30	35.0	50.0	24.5	34.5	19.5	15.0	24.050
* SO 51524-21,3	058.1540.213	64	28 x 1.5	32	36	39.5	54.5	28.5	35.5	20.5	19.0	36.290

Gerade Schottverschraubung reduziert

Durchführungslänge max. 16mm

Union double réduite pour passage de cloison

pour cloison max. 16mm

Panel mount reduction union

max. panel thickness 16mm

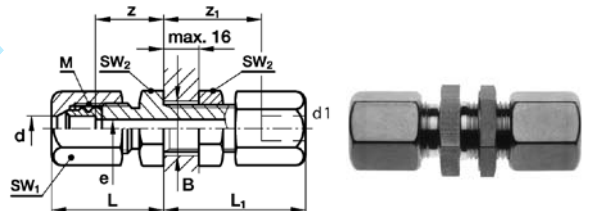

SO 51524 RED

Type-d-d1	Mat.-Nr.	bar	M	SW1	SW2	L1	L2	B	z1	z	e	kg/100
Für metrische Rohre	Pour tubes métriques			For metric tubes								
* SO 51524-15-12	058.1544.420	100	20 x 1.5	24	27	33.5	47.5	20.5	33.5	19.5	13.0	18.090
* SO 51524-15-14	058.1544.440	100	20 x 1.5	24	27	33.5	47.5	20.5	33.5	19.5	13.0	17.770
* SO 51524-18-15	058.1544.610	100	24 x 1.5	27	30	35.0	50.0	24.5	34.5	19.5	15.0	24.300
* SO 51524-18-16	058.1544.620	100	24 x 1.5	27	30	35.0	50.0	24.5	34.5	19.5	15.0	24.100

Für Zollrohre	Pour tubes pouces	For inch tubes										
SO 51524-15-12,7	058.1544.427	100	20 x 1.5	24	27	33.5	47.5	20.5	33.5	19.5	13.0	17.970
* SO 51524-15-13,5	058.1544.435	100	20 x 1.5	24	27	33.5	47.5	20.5	33.5	19.5	13.0	17.870
* SO 51524-18-17,2	058.1544.632	100	24 x 1.5	27	30	35.0	50.0	24.5	34.5	19.5	15.0	23.800

d=Rohrassen-ø
 e=kleinste Bohrung
 L=Mass in montiertem Zustand
 *=mit reduziertem Klemmring

d=ø extérieur du tube
 e=ø-min. de passage
 L=après montage
 *=with reduction compression ferrule

d=tube outside diameter
 e=minimum bore
 L= installed length
 *=with reduction compression ferrule

Einstellnippel

Union orientable mâle

Adjustable male adaptor

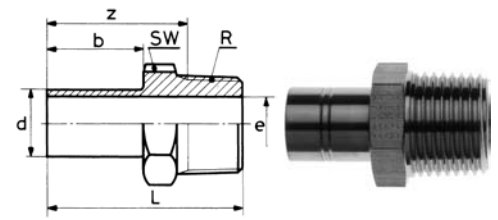

SO 51600

Type -Ad -R	Mat.-Nr.	bar	SW	L	b	z	e	kg/100
SO 51600-A4-1/8	056.1601.060	250	10	22.0	10.0	18.0	2.5	0.570
SO 51600-A5-1/8	056.1601.082	250	10	22.5	10.5	18.5	3.2	0.600
SO 51600-A6-1/8	056.1601.100	200	12	26.0	13.0	22.0	4.0	0.950
SO 51600-A6-1/4	056.1601.110	200	14	31.0	13.0	25.0	4.0	1.700
SO 51600-A8-1/8	056.1601.160	200	12	28.0	14.0	24.0	6.0	0.660
SO 51600-A8-1/4	056.1601.170	200	14	32.0	14.0	26.0	6.0	1.660
SO 51600-A10-1/4	056.1601.270	160	14	34.0	16.0	28.0	8.0	1.490
SO 51600-A10-3/8	056.1601.280	160	17	34.0	16.0	27.6	8.0	2.770
SO 51600-A10-1/2	056.1601.285	160	22	39.0	16.0	30.8	8.0	5.500
SO 51600-A12-1/4	056.1601.380	160	14	36.0	18.0	30.0	8.0	1.530
SO 51600-A12-3/8	056.1601.390	160	17	36.0	18.0	29.6	9.0	2.690
SO 51600-A12-1/2	056.1601.400	160	22	41.0	18.0	32.8	9.0	5.080
SO 51600-A15-1/2	056.1601.534	100	22	44.0	21.0	35.8	12.0	4.890

Anwendungsbeispiele:

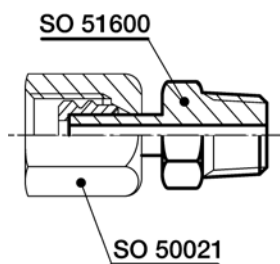

Exemples d'utilisation:

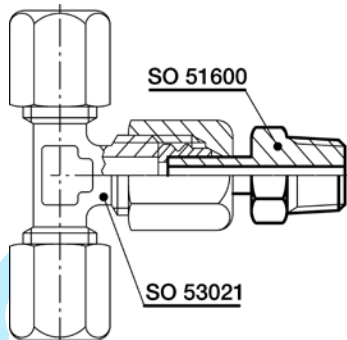

Sample combinations:

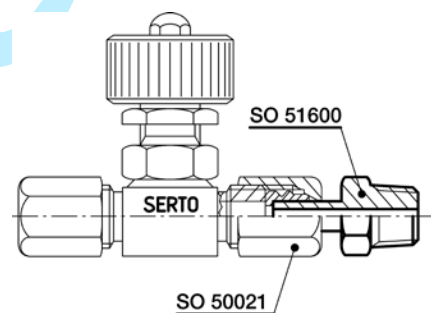

Dieser Einstellnippel ergibt im Zusammenhang mit unserem Armaturenanschluss SO 50021 einen einstellbaren Anschluss.

Kombinationsbeispiel:

Kombiniert mit Winkel- oder T-Verschraubungen ergeben sich einstellbare Formteile.

Cette pièce, montée avec un écrou SO 50021 permet d'obtenir un raccord orientable.

Exemples d'utilisation:

Cette pièce, combinée avec un coude ou un té, permet d'obtenir des raccords orientables.

In combination with our nut connection SO 50021, this adjustable male adaptor forms an adjustable male adaptor union.

Sample combinations:

Produces adjustable configurations in combination with elbow or tee unions.

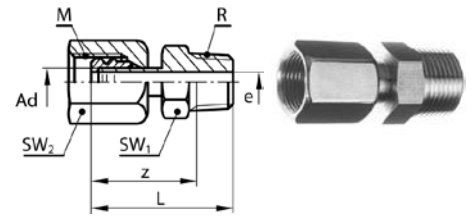
Einstellnippel vormontiert
Embout orientable mâle monté
Adjustable male adaptor assembly

SO 51625

Type -Ad-R	Mat.-Nr.	bar	M	SW1	SW2	L	z	e	kg/100
SO 51625-A4-1/8	058.1620.060	250	8 x 1	10	10	23.0	19.0	2.5	1.110
SO 51625-A5-1/8	058.1620.080	250	8 x 1	10	10	23.5	19.5	3.2	1.120
SO 51625-A6-1/8	058.1620.100	200	10 x 1	12	12	27.2	23.2	4.0	1.740
SO 51625-A6-1/4	058.1620.110	200	10 x 1	14	12	32.2	26.2	4.0	2.490
SO 51625-A8-1/8	058.1620.160	200	12 x 1	12	14	29.0	25.0	6.0	1.170
SO 51625-A8-1/4	058.1620.170	200	12 x 1	14	14	33.0	27.0	6.0	2.710
SO 51625-A10-1/4	058.1620.270	160	14 x 1	14	17	35.2	29.2	8.0	3.270
SO 51625-A10-3/8	058.1620.280	160	14 x 1	17	17	35.2	28.8	8.0	4.980
SO 51625-A10-1/2	058.1620.285	160	14 x 1	22	17	40.2	32.0	8.0	7.710
SO 51625-A12-1/4	058.1620.380	160	16 x 1	14	19	37.2	31.2	8.0	3.400
SO 51625-A12-3/8	058.1620.390	160	16 x 1	17	19	37.2	30.8	9.0	4.900
SO 51625-A12-1/2	058.1620.400	160	16 x 1	22	19	42.2	34.0	9.0	7.290
SO 51625-A15-1/2	058.1620.534	100	20 x 1.5	22	24	45.4	37.2	12.0	9.100

Reduktionsverschraubung

Réduction

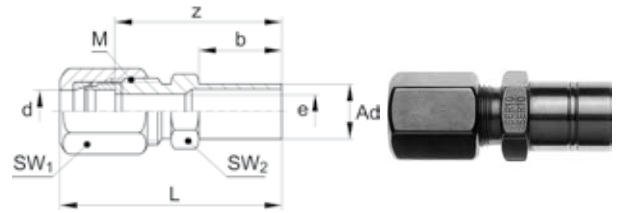
Reduced union



SO 51821

Type -Ad-d	Mat.-Nr.	bar	M	SW1	SW2	L	b	z	e	kg/100
Für metrische Rohre	Pour tubes métriques	For metric tubes								
* SO 51821-A10-4	058.1800.167	160	10 x 1	12	12	39.0	17.0	29.6	4.5	1.760
* SO 51821-A10-5	058.1800.170	160	10 x 1	12	12	39.0	17.0	29.6	4.5	1.720
SO 51821-A10-6	058.1800.175	160	10 x 1	12	12	39.0	17.0	29.6	4.5	1.670
* SO 51821-A12-6	058.1800.215	160	12 x 1	14	14	43.5	19.0	33.5	6.5	2.350
SO 51821-A12-8	058.1800.225	160	12 x 1	14	14	44.0	19.0	33.5	6.5	2.610
* SO 51821-A15-8	058.1800.400	100	14 x 1	17	17	49.0	21.0	36.2	8.5	4.130
SO 51821-A15-10	058.1800.410	100	14 x 1	17	17	49.0	21.0	36.2	8.5	3.940
* SO 51821-A18-10	058.1800.575	100	16 x 1	19	19	54.0	24.0	40.2	10.5	5.280
SO 51821-A18-12	058.1800.580	100	16 x 1	19	19	54.0	24.0	40.2	10.5	5.080
* SO 51821-A22-12	058.1800.730	64	20 x 1.5	24	24	59.5	25.0	43.5	13.0	8.920
SO 51821-A22-14	058.1800.740	64	20 x 1.5	24	24	60.0	25.0	43.5	13.0	8.600
SO 51821-A22-15	058.1800.745	64	20 x 1.5	24	24	60.0	25.0	43.5	13.0	8.360

Für Zollrohre	Pour tubes pouces	For inch tubes								
SO 51821-A10-6,35	058.1800.177	160	10 x 1	12	12	39.0	17.0	29.6	4.5	1.650
SO 51821-A15-9,52	058.1800.408	100	14 x 1	17	17	48.5	21.0	36.2	8.5	3.910
SO 51821-A22-12,7	058.1800.732	64	20 x 1.5	24	24	60.0	25.0	43.5	13.0	8.800
* SO 51821-A22-13,5	058.1800.737	64	20 x 1.5	24	24	60.0	25.0	43.5	13.0	8.700

Anwendungsbeispiele:

Exemples d'utilisation:

Sample combinations:

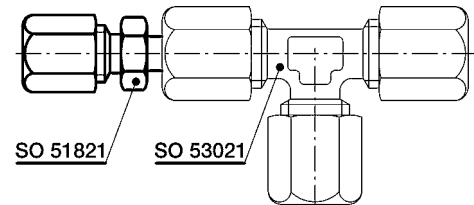
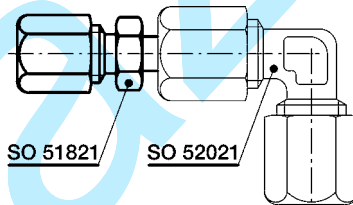
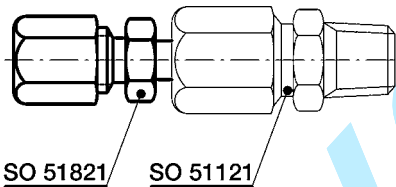

Die Reduktion SO 51821 lässt sich mit allen SERTO-Verschraubungen kombinieren. Die zylindrische Andrehung Ad wird in die Größe des SERTO-Anschlusses SO 50021 gesteckt und angezogen, somit ergeben sich weitere Rohrreduktionen.

La réduction SO 51821 peut se combiner avec tous les raccords SERTO. La portée cylindrique Ad s'emboîte et se serre dans la dimension d de l'écrou de raccordement SERTO SO 50021, donnant ainsi d'autres réductions de tube.

The reduction SO 51821 can be combined with all SERTO unions. The cyl. turned stub Ad is inserted in the bore d of the SERTO connection and tightened. This permits further tube reductions.

d=Rohrassens- \varnothing
Ad=Aussen- \varnothing der Andrehung
e= kleinste Bohrung
*=mit reduziertem Klemmring

d= \varnothing extérieur du tube
Ad= \varnothing extérieur de la portée cylindrique
e= \varnothing -min. de passage
*=avec bague de serrage de réduction

d=tube outside diameter
Ad=outside diameter of cyl. Stub
e=minimum bore
*=with reduction compression ferrule

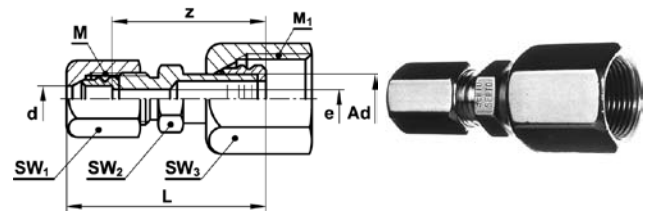
**Reduktionsverschraubung vor-
montiert**
Réduction montée
Reduction assembly
SO 51825

Type -Ad-d	Mat.-Nr.	bar	M	SW1	SW2	SW3	L	z	e	kg/100
Für metrische Rohre	Pour tubes métriques	For metric tubes								
* SO 51825-A10-4	058.1820.167	160	10 x 1	12	12	17	38.0	30.5	4.5	3.540
* SO 51825-A10-5	058.1820.170	160	10 x 1	12	12	17	38.0	30.5	4.5	3.500
SO 51825-A10-6	058.1820.175	160	10 x 1	12	12	17	38.0	30.5	4.5	3.450
* SO 51825-A12-6	058.1820.215	160	12 x 1	14	14	19	43.0	34.5	6.5	4.550
SO 51825-A12-8	058.1820.225	160	12 x 1	14	14	19	43.0	34.5	6.5	4.820
SO 51825-A15-8	058.1820.400	100	14 x 1	17	17	24	48.5	37.5	8.5	5.790
SO 51825-A15-10	058.1820.410	100	14 x 1	17	17	24	48.5	37.5	8.5	8.150
* SO 51825-A18-10	058.1820.575	100	16 x 1	19	19	27	53.5	41.5	10.5	10.300
SO 51825-A18-12	058.1820.580	100	16 x 1	19	19	27	53.5	41.5	10.5	10.130
* SO 51825-A22-12	058.1820.730	64	20 x 1.5	24	24	32	59.0	45.0	13.0	17.080
* SO 51825-A22-14	058.1820.740	64	20 x 1.5	24	24	32	59.0	45.0	13.0	16.760
SO 51825-A22-15	058.1820.745	64	20 x 1.5	24	24	32	59.0	45.0	13.0	16.520
Für Zollrohre	Pour tubes pouces	For inch tubes								
SO 51825-A10-6.35	058.1820.177	160	10 x 1	12	12	17	38.0	30.5	4.5	3.430
SO 51825-A12-6.35	058.1820.217	160	12 x 1	14	14	19	43.0	34.5	6.5	4.820
SO 51825-A15-9.52	058.1820.408	100	14 x 1	17	17	24	48.5	37.5	8.5	8.120
SO 51825-A22-12.7	058.1820.732	64	20 x 1.5	24	24	32	59.0	45.0	13.0	13.900
* SO 51825-A22-13.5	058.1820.737	64	20 x 1.5	24	24	32	59.0	45.0	13.0	13.250

d=Rohrassen-ø
 Ad=Aussen-ø der Andrehung
 e= kleinste Bohrung
 L= Mass in montiertem Zustand
 *=mit reduziertem Klemmring

d=ø extérieur du tube
 Ad=ø extérieur de la portée cylindrique
 e= ø-min. de passage
 L=après montage
 *=avec bague de serrage de réduction

d=tube outside diameter
 Ad= outside diameter of cyl. Stub
 e=minimum bore
 L=installed length
 *=with reduction compression ferrule

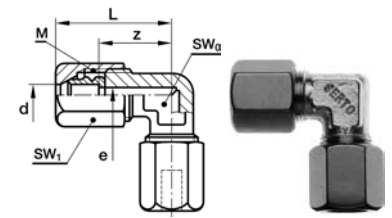
Winkelverschraubung
Coude
Elbow union

SO 52021

Type-d	Mat.-Nr.	bar	M	SW0	SW1	L	z	e	kg/100
Für metrische Rohre	Pour tubes métriques		For metric tubes						
* SO 52021-2	058.2000.020	250	8 x 1	9	10	23.0	16.0	3.5	1.980
* SO 52021-3	058.2000.030	250	8 x 1	9	10	23.5	16.0	3.5	1.970
SO 52021-4	058.2000.040	250	8 x 1	9	10	21.5	16.0	3.5	1.950
SO 52021-5	058.2000.050	250	8 x 1	9	10	22.0	16.0	3.5	1.900
SO 52021-6	058.2000.060	200	10 x 1	9	12	23.5	16.0	4.5	2.730
SO 52021-8	058.2000.080	200	12 x 1	10	14	27.0	18.0	6.5	3.740
SO 52021-10	058.2000.100	160	14 x 1	12	17	31.5	20.5	8.5	5.900
SO 52021-12	058.2000.120	160	16 x 1	14	19	33.5	21.5	9.5	7.530
* SO 52021-14	058.2000.140	100	20 x 1.5	17	24	38.0	24.5	13.0	13.150
SO 52021-15	058.2000.150	100	20 x 1.5	17	24	38.0	24.5	13.0	12.910
* SO 52021-16	058.2000.160	100	24 x 1.5	22	27	42.0	26.5	15.0	18.200
SO 52021-18	058.2000.180	100	24 x 1.5	22	27	42.0	26.5	15.0	17.650
SO 52021-22	058.2000.220	64	28 x 1.5	27	32	49.5	30.5	19.0	27.180
Für Zollrohre	Pour tubes pouces		For inch tubes						
SO 52021-6,35	058.2000.063	200	10 x 1	9	12	23.5	16.0	4.5	2.690
SO 52021-9,52	058.2000.095	160	14 x 1	12	17	31.5	20.5	8.5	5.960
SO 52021-12,7	058.2000.127	100	20 x 1.5	17	24	38.0	24.5	13.0	13.790
* SO 52021-13,5	058.2000.135	100	20 x 1.5	17	24	38.0	24.5	13.0	13.250
* SO 52021-17,2	058.2000.172	100	24 x 1.5	22	27	42.0	26.5	15.0	17.900
* SO 52021-21,3	058.2000.213	64	28 x 1.5	27	32	49.5	30.5	19.0	28.580

d=Rohrassen-ø
 e= kleinste Bohrung
 L= Mass in montiertem Zustand
 *=mit reduziertem Klemmring

d=ø extérieur du tube
 e= ø-min. de passage
 L=après montage
 *=avec bague de serrage de réduction

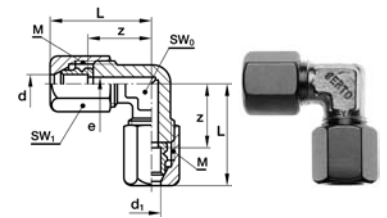
d=tube outside diameter
 e=minimum bore
 L=installed length
 *=with reduction compression ferrule

Winkelverschraubung reduziert
Coude réduit
Elbow reduction union

SO 52021 RED

Type - d - d1	Mat.-Nr.	bar	M	SW0	SW1	L	z	e	kg/100
Für metrische Rohre	Pour tubes métriques	For metric tubes							
* SO 52021-5-3	058.2004.060	250	8 x 1	9	10	22.0	16.0	3.5	1.830
* SO 52021-6-4	058.2004.110	200	10 x 1	9	12	24.0	16.0	4.5	2.820
* SO 52021-6-5	058.2004.117	200	10 x 1	9	12	24.0	16.0	4.5	2.780
* SO 52021-8-6	058.2004.140	200	12 x 1	10	14	26.5	18.0	6.5	3.900
* SO 52021-10-8	058.2004.190	160	14 x 1	12	17	31.5	20.5	8.5	6.090
* SO 52021-12-10	058.2004.240	160	16 x 1	14	19	33.5	21.5	9.5	7.760
* SO 52021-15-12	058.2004.420	100	20 x 1.5	17	24	38.5	24.5	13.0	13.470
* SO 52021-15-14	058.2004.440	100	20 x 1.5	17	24	38.5	24.5	13.0	13.150
* SO 52021-18-15	058.2004.610	100	24 x 1.5	22	27	42.0	26.5	15.0	18.400
* SO 52021-18-16	058.2004.620	100	24 x 1.5	22	27	42.0	26.5	15.0	18.200
* SO 52021-22-18	058.2004.755	64	28 x 1.5	27	32	49.5	30.5	19.0	29.780
Für Zollrohre	Pour tubes pouces	For inch tubes							
SO 52021-6-6,35	058.2004.119	200	10 x 1	9	12	24.0	16.0	4.5	2.720
SO 52021-10-9,52	058.2004.197	160	14 x 1	12	17	31.5	20.5	8.5	5.930
SO 52021-15-12,7	058.2004.427	100	20 x 1.5	17	24	38.5	24.5	13.0	13.350
* SO 52021-15-13,5	058.2004.435	100	20 x 1.5	17	24	38.5	24.5	13.0	13.250
* SO 52021-18-17,2	058.2004.632	100	24 x 1.5	22	27	42.0	26.5	15.0	17.900
* SO 52021-22-21,3	058.2004.785	64	28 x 1.5	27	32	49.5	30.5	19.0	28.580

Weitere Reduktionen siehe SO 51821

Autres réductions voir SO 51821

Alternative reductions see SO 51821

d/d1=Rohrassen-ø
 e= kleinste Bohrung
 L= Mass in montiertem Zustand
 *=mit reduziertem Klemmring

d/d1=ø extérieur du tube
 e= ø-min. de passage
 L=après montage
 *=avec bague de serrage de réduction

d/d1=tube outside diameter
 e=minimum bore
 L=installed length
 *=with reduction compression ferrule

Winkelverschraubung

mit Übergangsnippel

Coûde

avec adaptateur mâle

Elbow union

with male adaptor

SO 52121

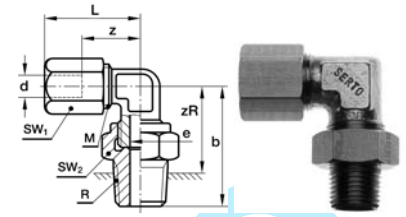

Type -d -R	Mat.-Nr.	bar	M	SW1	SW2	L	b	zR	z	e	kg/100
Für metrische Rohre	Pour tubes métriques			For metric tubes							
SO 52121-8-1/8	058.2101.160	200	12 x 1	14	14	26.5	28.0	24.0	18.0	6.5	3.670
SO 52121-10-1/2	058.2101.285	160	14 x 1	17	22	31.5	35.5	27.3	20.5	8.5	8.730
* SO 52121-16-1/2	058.2101.566	100	24 x 1.5	27	30	42.0	46.0	37.8	26.5	15.0	19.170
SO 52121-18-1/2	058.2101.646	100	24 x 1.5	27	30	42.0	46.0	37.8	26.5	15.0	18.620
SO 52121-18-3/4	058.2101.648	64	28 x 1.5	32	36	49.5	50.5	41.0	30.5	16.0	29.640
SO 52121-22-3/4	058.2101.768	64	28 x 1.5	32	36	49.5	50.5	41.0	30.5	19.0	29.640
Für Zollrohre	Pour tubes pouces			For inch tubes							
SO 52121-9,52-1/2	058.2101.240	160	14 x 1	17	22	31.5	35.5	27.3	20.5	8.5	8.760
* SO 52121-17,2-1/2	058.2101.616	100	24 x 1.5	27	30	42.0	46.0	37.8	26.5	15.0	18.870
* SO 52121-21,3-3/4	058.2101.738	64	28 x 1.5	32	36	49.5	50.5	41.0	30.5	19.0	29.640

Winkelverschraubung

mit Übergangsnippel NPT

Coûde

avec adaptateur mâle NPT

Elbow union

with male adaptor NPT

SO 52121 NPT

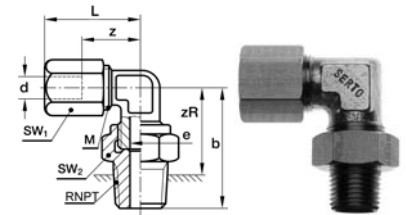

Type -d -RNPT	Mat.-Nr.	bar	M	SW1	SW2	L	b	zR	z	e	kg/100
RNPT=NPT Gewinde	RNPT=Filetage NPT			RNPT=NPT thread							
SO 52121-12-1/4 NPT	058.2102.380	160	16 x 1	19	19	33.5	38.5	32.7	21.5	9.5	7.390

5

d=Rohrassen-ø
e= kleinste Bohrung
L= Mass in montiertem Zustand
*=mit reduziertem Klemmring

d=ø extérieur du tube
e= ø-min. de passage
L=après montage
*=avec bague de serrage de réduction

d=tube outside diameter
e=minimum bore
L=installed length
*=with reduction compression ferrule

Winkelverschraubung

mit Übergangsnippel METR

Coude

avec adaptateur mâle METR

Elbow union

with male adaptor METR

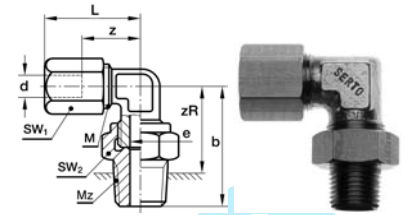

SO 52121 METR

Type -d-Mz	Mat.-Nr.	bar	M	SW1	SW2	L	b	zR	z	e	kg/100
Mz=metrisches Gewinde (zylindrisch)	Mz=Filetage métrique (cylindrique)	Mz=Metric thread (straight)									
* SO 52121-3-M6X0,75	058.2143.055	250	8 x 1	10	10	24.0	26.0	22.0	18.0	6.5	1.750
* SO 52121-3-M8X1	058.2143.060	250	8 x 1	10	10	24.0	26.0	23.0	18.0	6.5	1.860
SO 52121-4-M6X0,75	058.2143.085	250	8 x 1	10	10	24.0	26.0	22.0	18.0	6.5	1.700
SO 52121-4-M8X1	058.2143.090	250	8 x 1	10	10	24.0	26.0	23.0	18.0	6.5	1.810
SO 52121-5-M6X0,75	058.2143.115	250	8 x 1	10	10	24.0	26.0	22.0	18.0	6.5	1.680
SO 52121-5-M8X1	058.2143.125	250	8 x 1	10	10	24.0	26.0	23.0	18.0	6.5	1.790

Der Übergangsnippel SO 50040 kann an jedes SERTO-Formteil anstelle des Armaturenanschlusses SO 50021 mit dem passenden Gewinde aufgeschraubt werden. In Verbindung mit den Formteilen ist der Übergangsnippel SO 50040 nur lose aufgeschraubt und muss bei der Montage angezogen werden. Dichtungsprinzip siehe SO 50040. Die Bestellnummer für eine Winkelverschraubung mit aufgeschraubtem Übergangsnippel SO 50040 lautet SO 52121-d-G1.

L'adaptateur mâle SO 50040 peut être monté sur toutes les pièces de forme SERTO avec le filetage correspondant, au lieu et place de l'écrou SO 50021. En cas de livraison avec des pièces SERTO, l'adaptateur SO 50040 n'est que très légèrement vissé et doit être resserré lors du montage. Principe de l'étanchéité et filetage voir SO 50040. No de commande pour un coude avec adaptateur SO 50040 = SO 52121-d-G1. Exemples d'utilisation voir page Coude mâle SO 52421.

The male adaptor SO 50040 can be fitted to any SERTO forged body in place of the nut connection SO 50021 with the relevant straight thread. Combinations are supplied with the male adaptor SO 50040 screwed only loosely on the body. It must be tightened for installation. See SO 50040 for sealing principle. The order No. for an elbow union complete with male adaptor SO 50040 is SO 52121-d-G1.

d=Rohrassen-ø
e= kleinste Bohrung
L= Mass in montiertem Zustand
*=mit reduziertem Klemmring

d=ø extérieur du tube
e= ø-min. de passage
L=après montage
*=avec bague de serrage de réduction

d=tube outside diameter
e=minimum bore
L=installed length
*=with reduction compression ferrule

Winkelverschraubung

mit Übergangsmuffe

Coude

avec adaptateur femelle

Elbow union

with female adaptor

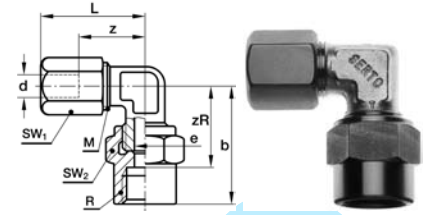
SO 52221

Type -d-R	Mat.-Nr.	bar	M	SW1	SW2	L	b	zR	z	e	kg/100
Für metrische Rohre	Pour tubes métriques					For metric tubes					
SO 52221-10- ³ / ₈	058.2201.280	160	14 x 1	17	22	31.5	35.5	23.5	20.5	8.5	8.170
★ SO 52221-4- ¹ / ₈	058.2201.060	200	10 x 1	12	14	24.0	29.0	19.0	16.0	4.5	3.500
★ SO 52221-5- ¹ / ₈	058.2201.082	200	10 x 1	12	14	24.0	29.0	19.0	16.0	4.5	3.470
SO 52221-6- ¹ / ₈	058.2201.100	200	10 x 1	12	14	24.0	29.0	19.0	16.0	4.5	3.420
SO 52221-6- ¹ / ₄	058.2201.110	200	12 x 1	14	17	26.5	33.0	22.0	18.0	6.5	4.680
SO 52221-8- ¹ / ₈	058.2201.160	200	12 x 1	14	17	26.5	31.0	21.0	18.0	6.5	5.250
SO 52221-8- ¹ / ₄	058.2201.170	200	12 x 1	14	17	26.5	33.0	22.0	18.0	6.5	4.840
★ SO 52221-8- ³ / ₈	058.2201.180	160	14 x 1	17	22	31.5	35.5	23.5	20.5	8.5	8.360
SO 52221-10- ¹ / ₄	058.2201.270	160	14 x 1	17	17	31.5	34.5	23.5	20.5	8.5	5.990
SO 52221-12- ³ / ₈	058.2201.390	160	16 x 1	19	22	33.5	36.5	24.5	21.5	9.5	9.040
★ SO 52221-12- ¹ / ₂	058.2201.400	100	20 x 1.5	24	27	38.5	42.0	28.0	24.5	13.0	16.390
★ SO 52221-14- ¹ / ₂	058.2201.504	100	20 x 1.5	24	27	38.5	42.0	28.0	24.5	13.0	15.540
SO 52221-15- ¹ / ₂	058.2201.534	100	20 x 1.5	24	27	38.5	42.0	28.0	24.5	13.0	15.300
★ SO 52221-16- ¹ / ₂	058.2201.566	100	24 x 1.5	27	30	42.0	45.0	31.0	26.5	15.0	21.960
SO 52221-18- ¹ / ₂	058.2201.646	100	24 x 1.5	27	30	42.0	45.0	31.0	26.5	15.0	21.410
Für Zollrohre	Pour tubes pouces					For inch tubes					
SO 52221-6,35- ¹ / ₈	058.2201.135	200	10 x 1	12	14	24.0	29.0	19.0	16.0	4.5	3.400
SO 52221-9,52- ¹ / ₄	058.2201.230	160	14 x 1	17	17	31.5	34.5	23.5	20.5	8.5	6.020
SO 52221-9,52- ³ / ₈	058.2201.235	160	14 x 1	17	22	31.5	35.5	23.5	20.5	8.5	8.200
SO 52221-12,7- ¹ / ₂	058.2201.434	100	20 x 1.5	24	27	38.5	42.0	28.0	24.5	13.0	16.270
★ SO 52221-13,5- ¹ / ₂	058.2201.474	100	20 x 1.5	24	27	38.5	42.0	28.0	24.5	13.0	15.640
★ SO 52221-17,2- ¹ / ₂	058.2201.616	100	24 x 1.5	27	30	42.0	45.0	31.0	26.5	15.0	21.660

Die Übergangsmuffe SO 50030 kann an jedes SERTO-Formteil anstelle des Armaturenanschlusses SO 50021 mit dem passenden Gewinde aufgeschraubt werden. In Verbindung mit den Formteilen ist die Übergangsmuffe SO 50030 nur lose aufgeschraubt und muss bei der Montage angezogen werden. Dichtungsprinzip siehe SO 50030. Die Bestellnummer für die Winkelverschraubung mit aufgeschraubter Übergangsmuffe SO 50030 lautet SO 52221-d-G.

L'adaptateur femelle SO 50030 peut être monté sur toutes les pièces de forme SERTO avec le filetage correspondant, au lieu et place de l'écrou SO 50021. En cas de livraison avec des pièces SERTO, l'adaptateur SO 50030 n'est que très légèrement vissé et doit être resserré lors du montage. Principe de l'étanchéité et filetage voir SO 50030. No de commande pour un coude avec adaptateur SO 50030 = SO 52221-d-G.

The female adaptor SO 50030 can be fitted to any SERTO forged body in place of the nut connection SO 50021 with the relevant straight thread. Combinations are supplied with the female adaptor SO 50030 screwed only loosely on the body. It must be tightened for installation. See SO 50030 for sealing principle. The order No. for the elbow union complete with female adaptor SO 50030 is SO 52221-d-G.

d=Rohrassen-ø
e= kleinste Bohrung
L= Mass in montiertem Zustand
*=mit reduziertem Klemmring

d=ø extérieur du tube
e= ø-min. de passage
L=après montage
*=avec bague de serrage de réduction

d=tube outside diameter
e=minimum bore
L=installed length
*=with reduction compression ferrule

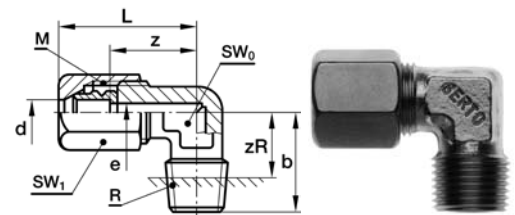
Winkel-Einschraubverschraubung
Coude mâle
Male adaptor elbow union

SO 52421

Type -d-R	Mat.-Nr.	bar	M	SW0	SW1	L	b	zR	z	e	kg/100	
Für metrische Rohre	Pour tubes métriques			For metric tubes								
* SO 52421-2-1/8	058.2401.020	250	8 x 1	9	10	23.0	17.0	13.0	16.0	1.5	1.740	
* SO 52421-3-1/8	058.2401.040	250	8 x 1	9	10	21.5	17.0	13.0	16.0	3.5	1.700	
SO 52421-4-1/8	058.2401.060	250	8 x 1	9	10	21.5	17.0	13.0	16.0	3.5	1.620	
SO 52421-5-1/8	058.2401.082	250	8 x 1	9	10	21.5	17.0	13.0	16.0	3.5	1.600	
SO 52421-6-1/8	058.2401.100	200	10 x 1	9	12	23.5	17.5	13.5	16.0	4.5	2.090	
SO 52421-6-1/4	058.2401.110	200	10 x 1	10	14	26.5	22.5	18.5	18.0	4.5	3.410	
SO 52421-8-1/8	058.2401.160	200	12 x 1	10	14	26.0	19.0	13.5	18.0	6.0	2.670	
SO 52421-8-1/4	058.2401.170	200	12 x 1	10	14	26.5	22.5	18.5	18.0	6.5	3.250	
SO 52421-8-3/8	058.2401.180	200	12 x 1	14	14	30.5	27.0	19.0	22.5	6.5	5.510	
SO 52421-10-1/4	058.2401.270	160	14 x 1	12	17	31.5	25.0	19.0	20.5	8.5	4.220	
* SO 52421-10-3/8	058.2401.280	160	16 x 1	14	19	33.5	26.0	19.6	21.5	10.5	6.110	
SO 52421-12-1/4	058.2401.380	160	16 x 1	14	19	33.5	25.3	18.9	21.5	8.5	5.120	
SO 52421-12-3/8	058.2401.390	160	16 x 1	14	19	33.5	26.0	19.6	21.5	10.5	5.910	
* SO 52421-12-1/2	058.2401.400	100	20 x 1.5	17	24	38.0	29.5	21.3	24.5	13.0	10.240	
* SO 52421-14-1/2	058.2401.504	100	20 x 1.5	17	24	38.0	29.5	21.3	24.5	13.0	9.920	
SO 52421-15-1/2	058.2401.534	100	20 x 1.5	17	24	38.0	29.5	21.3	24.5	13.0	9.680	
SO 52421-18-1/2	058.2401.646	100	24 x 1.5	24	27	49.0	35.0	26.8	33.5	15.0	18.100	
SO 52421-22-3/4	058.2401.768	64	28 x 1.5	27	32	56.5	45.0	35.5	37.5	19.0	27.200	
Für Zollrohre	Pour tubes pouces			For inch tubes								
SO 52421-6,35-1/8	058.2401.135	200	10 x 1	9	12	23.5	17.5	13.5	16.0	4.5	2.000	
* SO 52421-6,35-1/4	058.2401.140	200	12 x 1	10	14	26.5	22.5	18.5	18.0	6.5	3.400	
SO 52421-9,52-1/4	058.2401.230	160	14 x 1	12	17	31.5	25.0	19.0	20.5	8.5	4.250	
SO 52421-12,7-1/2	058.2401.434	100	20 x 1.5	17	24	38.0	29.5	21.3	24.5	13.0	10.120	
* SO 52421-13,5-1/2	058.2401.474	100	20 x 1.5	17	24	38.0	29.5	21.3	24.5	13.0	10.020	

Weitere Einschraubwinkel siehe SO 52121.

Autres coudes mâles voir SO 52121.

Alternative elbow union see SO 52121.

d=Rohrassen-ø
 e= kleinste Bohrung
 L= Mass in montiertem Zustand
 *=mit reduziertem Klemmring

d=ø extérieur du tube
 e= ø-min. de passage
 L=après montage
 *=avec bague de serrage de réduction

d=tube outside diameter
 L=installed length
 e=minimum bore
 *=with reduction compression ferrule

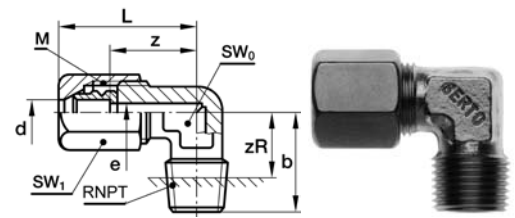
Winkel-Einschraubverschraubung NPT
Coude mâle NPT
Male adaptor elbow union NPT

SO 52421 NPT

Type -d -RNPT	Mat.-Nr.	bar	M	SW0	SW1	L	b	zR	z	e	kg/100
Für metrische Rohre RNPT=NPT Gewinde	Pour tubes métriques RNPT=Filetage NPT	For metric tubes RNPT=NPT thread									
* SO 52421-3-1/8 NPT	058.2402.040	250	8 x 1	9	10	21.5	17.0	13.0	16.0	3.5	1.530
* SO 52421-4-1/8 NPT	058.2402.060	250	8 x 1	9	10	21.5	17.0	13.0	16.0	3.5	1.460
SO 52421-5-1/8 NPT	058.2402.082	250	8 x 1	9	10	21.5	17.0	13.0	16.0	3.5	1.440
SO 52421-6-1/8 NPT	058.2402.100	200	10 x 1	9	12	23.5	17.5	13.5	16.0	4.5	1.900
* SO 52421-6-1/4 NPT	058.2402.110	200	12 x 1	10	14	26.5	22.5	18.5	18.0	6.5	3.330
SO 52421-8-1/4 NPT	058.2402.170	200	12 x 1	10	14	26.5	22.5	18.5	18.0	6.5	3.170
SO 52421-10-1/4 NPT	058.2402.270	160	14 x 1	12	17	31.5	25.0	19.2	20.5	8.5	4.280
* SO 52421-10-3/8 NPT	058.2402.280	160	16 x 1	14	19	33.5	26.0	20.0	21.5	10.5	6.060
SO 52421-12-3/8 NPT	058.2402.390	160	16 x 1	14	19	33.5	26.0	20.0	21.5	10.5	5.860
* SO 52421-12-1/2 NPT	058.2402.400	100	20 x 1.5	17	24	38.0	29.5	21.3	24.5	13.0	10.130
* SO 52421-14-1/2 NPT	058.2402.504	100	20 x 1.5	17	24	38.0	29.5	21.3	24.5	13.0	9.810
* SO 52421-15-1/2 NPT	058.2402.534	100	20 x 1.5	17	24	38.0	29.5	21.3	24.5	13.0	9.570
Für Zollrohre	Pour tubes pouces	For inch tubes									
SO 52421-6,35-1/8 NPT	058.2402.135	200	10 x 1	9	12	23.5	17.5	13.5	16.0	4.5	1.880
* SO 52421-6,35-1/4 NPT	058.2402.140	200	12 x 1	10	14	26.5	22.5	18.5	18.0	6.5	3.300
SO 52421-9,52-1/4 NPT	058.2402.230	160	14 x 1	12	17	31.5	25.0	19.2	20.5	8.5	4.310
SO 52421-12,7-1/2 NPT	058.2402.434	100	20 x 1.5	17	24	38.0	29.5	21.3	24.5	13.0	10.010
* SO 52421-13,5-1/2 NPT	058.2402.474	100	20 x 1.5	17	24	38.0	29.5	21.3	24.5	13.0	9.910

Weitere Einschraubwinkel siehe SO 52121.

Autres coudes mâles voir SO 52121.

Alternative elbow union see SO 52121.

d=Rohrassen-ø
 e= kleinste Bohrung
 L= Mass in montiertem Zustand
 *=mit reduziertem Klemmring

d=ø extérieur du tube
 e= ø-min. de passage
 L=après montage
 *=avec bague de serrage de réduction

d=tube outside diameter
 L=installed length
 e=minimum bore
 *=with reduction compression ferrule

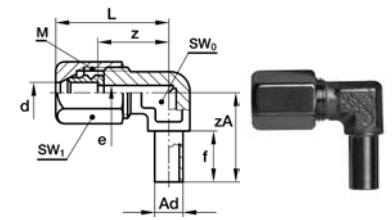
Einstellwinkel
Coude orientable
Adjustable elbow union

SO 52621

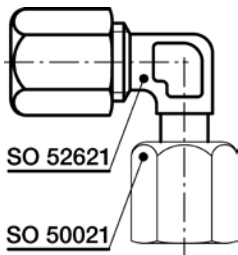
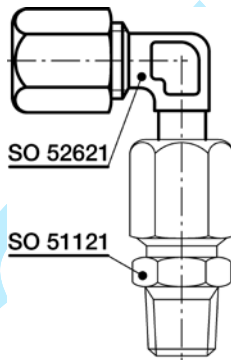
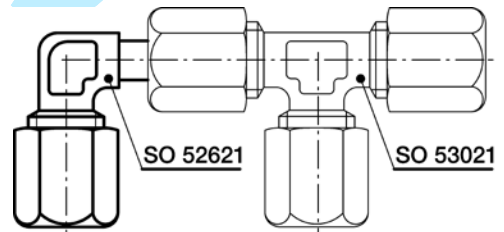
Type - d - Ad	Mat.-Nr.	bar	M	SW0	SW1	L	f	zA	z	e	kg/100
Für metrische Rohre	Pour tubes métriques			For metric tubes							
* SO 52621-4-A6	058.2600.045	200	10 x 1	9	12	24.0	12.5	18.0	16.0	4.0	1.780
* SO 52621-5-A6	058.2600.053	200	10 x 1	9	12	24.0	12.5	18.0	16.0	4.0	1.760
SO 52621-6-A6	058.2600.060	200	10 x 1	9	12	24.0	12.5	18.0	16.0	4.0	1.710
* SO 52621-6-A8	058.2600.063	200	12 x 1	10	14	28.5	15.0	23.0	18.0	6.0	2.630
SO 52621-8-A8	058.2600.080	200	12 x 1	10	14	28.5	15.0	23.0	18.0	6.0	2.430
* SO 52621-8-A10	058.2600.083	160	14 x 1	12	17	31.5	17.0	25.5	20.5	8.0	4.050
SO 52621-10-A10	058.2600.100	160	14 x 1	12	17	31.5	17.0	25.5	20.5	8.0	3.880
SO 52621-12-A12	058.2600.120	160	16 x 1	14	19	33.5	18.0	26.5	21.5	9.0	5.500
SO 52621-15-A15	058.2600.150	100	20 x 1.5	17	24	38.0	19.5	30.0	24.5	12.4	9.800
SO 52621-18-A18	058.2600.180	100	24 x 1.5	24	27	45.0	25.0	48.0	29.5	15.0	7.400
Für Zollrohre	Pour tubes pouces			For inch tubes							
SO 52621-6,35-A6	058.2600.067	200	10 x 1	9	12	24.0	12.0	18.0	16.0	4.0	1.710

Anwendungsbeispiele:

Exemples d'utilisation:

Sample combinations:

Die Winkelverschraubung SO 52621 ergibt im Zusammenhang mit unserem Armaturenanschluss SO 50021 einen einstellbaren Winkelanschluss. Gegenüber dem Einschraubwinkel lässt sich diese Kombination einfacher einstellen, da Einschrauben und Ausrichten getrennt voneinander vorgenommen werden.

L'assemblage du SO 52621 et d'un écrou SO 50021 donne un coude orientable. Par rapport au coude mâle, cette combinaison permet un positionnement plus facile, car l'emboîtement et l'alignement s'ajustent séparément.

In combination with our nut connection SO 50021 this elbow forms an adjustable female adaptor elbow. In contrast to the simple male adaptor elbow union, this combination is easier to adjust, since screw-on and aligning are performed separately.

d=Rohrassens- \varnothing
 Ad=Aussen- \varnothing der Andrehung
 e= kleinste Bohrung
 L= Mass in montiertem Zustand
 *=mit reduziertem Klemmring

d= \varnothing extérieur du tube
 Ad= \varnothing extérieur de la portée cylindrique
 e= \varnothing -min. de passage
 L=après montage
 *=avec bague de serrage de réduction

d=tube outside diameter
 Ad=outside diameter of cyl. Stub
 e=minimum bore
 L=installed length
 *=with reduction compression ferrule

Winkelverschraubung

mit Einstellzapfen vormontiert

Coude orientable monté

Adjustable elbow assembly

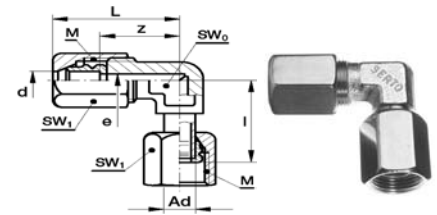

SO 52625

Type -d -Ad	Mat.-Nr.	bar	M	SW0	SW1	L	I	z	e	kg/100
Für metrische Rohre	Pour tubes métriques	For metric tubes								
* SO 52625-4-A6	058.2620.045	200	10 x 1	9	12	23.5	19.0	16.0	4.0	2.570
* SO 52625-5-A6	058.2620.053	200	10 x 1	9	12	23.5	19.0	16.0	4.0	2.550
SO 52625-6-A6	058.2620.060	200	10 x 1	9	12	23.5	19.0	16.0	4.0	2.500
* SO 52625-6-A8	058.2620.063	200	12 x 1	10	14	26.0	24.2	18.0	6.0	3.800
SO 52625-8-A8	058.2620.080	200	12 x 1	10	14	28.5	24.2	18.0	6.0	3.480
* SO 52625-8-A10	058.2620.083	160	14 x 1	12	17	30.5	26.7	20.5	7.5	5.830
SO 52625-10-A10	058.2620.100	160	14 x 1	12	17	30.5	26.7	20.5	7.5	5.660
SO 52625-12-A12	058.2620.120	100	16 x 1	14	19	32.5	27.7	21.5	9.0	7.280
SO 52625-15-A15	058.2620.150	100	20 x 1.5	17	24	37.9	31.4	24.5	12.4	8.040
Für Zollrohre	Pour tubes pouces	For inch tubes								
SO 52625-6.35-A6	058.2620.067	200	10 x 1	12	12	23.5	19.0	16.0	4.0	2.500

Winkel-Schottverschraubung

Durchführungslänge max. 20 mm

Coude pour passage de cloison

pour cloison max. 20 mm

Panel mount elbow union

max. panel thickness 20 mm

SO 52721

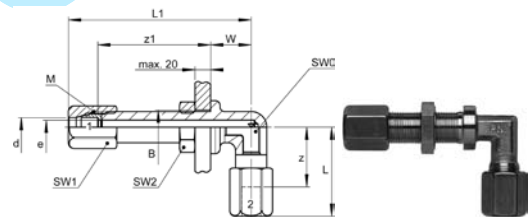

Type -d	Mat.-Nr.	bar	M	SW0	SW1	SW2	L	L1	W	z1	z	e	kg/100
Für metrische Rohre	Pour tubes métriques	For metric tubes											
SO 52721-6	058.2700.060	200	10 x 1	12	12	14	27.0	57.0	13.0	36.0	19.0	4.5	6.980
SO 52721-8	058.2700.080	200	12 x 1	12	14	17	27.5	58.0	13.0	36.0	19.0	5.5	9.450
SO 52721-10	058.2700.100	160	14 x 1	12	17	19	34.5	64.5	17.0	36.0	23.0	7.5	12.350
SO 52721-12	058.2700.120	160	16 x 1	14	19	22	36.5	66.5	17.0	37.0	24.0	8.5	17.060
SO 52721-15	058.2700.150	100	20 x 1.5	19	24	27	43.5	77.5	23.0	40.0	29.5	13.0	28.600
SO 52721-18	058.2700.180	100	24 x 1.5	24	27	30	49.0	80.0	22.0	42.5	33.5	15.0	30.600
SO 52721-22	058.2700.220	64	28 x 1.5	27	32	36	56.0	94.5	28.0	46.5	37.5	19.0	31.800

M=Anschlussgewinde
 l=Einbaulänge
 e=kleinste Bohrung
 L=Mass in montiertem Zustand
 *=mit reduziertem Klemmring

M=filetage
 l=longueur encastrée
 e=ø-min. de passage
 L=après montage
 *=avec bague de serrage de réduction

M=thread
 l=fitted length
 e=minimum bore
 L=installed length
 *=with reduction compression ferrule

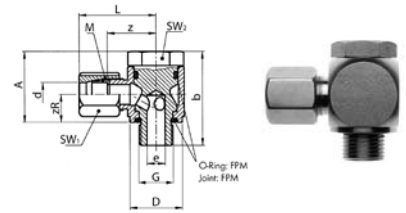
Schwenkverschraubung
Coude banjo
Single banjo

SO 52824

Type -d-G	Mat.-Nr.	bar	M	SW1	SW2	L	A	b	D	zR	z	e	kg/100
Für metrische Rohre	Pour tubes métriques			For metric tubes									
G=Rohrgewinde (zylindrisch)	G=Filetage-gaz BSP (cylindrique)			G=BSP thread (straight)									
* SO 52824-4-1/8	058.2841.060	200	10 x 1	12	14	25.0	23.0	31.0	17.0	9.0	18.0	4.5	5.000
* SO 52824-5-1/8	058.2841.082	200	10 x 1	12	14	25.5	23.0	31.0	17.0	9.0	18.0	4.5	4.950
SO 52824-6-1/8	058.2841.100	200	10 x 1	12	14	27.5	23.0	31.0	17.0	9.0	18.0	4.5	4.900
* SO 52824-6-1/4	058.2841.110	200	12 x 1	14	19	30.0	27.5	38.0	20.5	12.0	20.5	7.0	10.100
SO 52824-8-1/8	058.2841.160	200	10 x 1	12	14	29.5	23.0	31.0	18.0	10.5	19.0	4.5	6.300
SO 52824-8-1/4	058.2841.170	200	12 x 1	14	19	31.0	27.5	38.0	20.5	12.0	20.5	7.0	9.950
SO 52824-10-1/4	058.2841.270	160	14 x 1	17	19	31.5	27.5	38.0	20.5	12.0	20.5	7.0	10.800
* SO 52824-10-3/8	058.2841.280	160	16 x 1	19	24	37.0	37.0	49.0	26.0	15.0	24.0	9.0	17.200
SO 52824-12-3/8	058.2841.390	160	16 x 1	19	24	38.0	37.0	49.0	26.0	15.0	24.0	9.0	16.800
* SO 52824-12-1/2	058.2841.400	160	20 x 1.5	24	27	42.5	41.5	57.0	31.5	18.0	28.5	12.0	32.200
* SO 52824-14-1/2	058.2841.504	100	20 x 1.5	24	27	41.5	43.5	57.0	31.5	18.0	28.5	12.0	31.800
SO 52824-15-1/2	058.2841.534	100	20 x 1.5	24	27	41.5	43.5	57.0	31.5	18.0	28.5	12.0	31.600
SO 52824-18-1/2	058.2841.646	100	24 x 1.5	27	27	46.5	41.5	55.0	31.5	17.0	28.5	12.0	32.800

Für Zollrohre

Pour tubes pouces

For inch tubes

SO 52824-6,35-1/8	058.2841.135	200	10 x 1	12	14	27.5	21.0	31.0	17.0	9.0	18.0	4.5	4.900
SO 52824-9,52-1/4	058.2841.230	160	14 x 1	17	19	33.0	27.0	38.0	20.5	12.0	20.5	7.0	10.800
SO 52824-12,7-1/2	058.2841.434	160	20 x 1.5	24	27	44.5	41.5	57.0	31.5	18.0	28.5	12.0	32.000

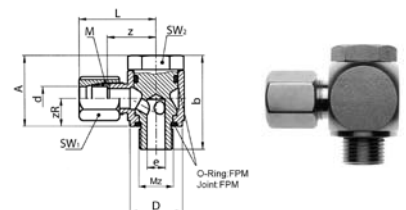
Schwenkverschraubung METR
Coude banjo METR
Single banjo METR

SO 52824 METR

Type -d-Mz	Mat.-Nr.	bar	M	SW1	SW2	L	A	b	D	zR	z	e	kg/100
Für metrische Rohre	Pour tubes métriques			For metric tubes									
SO 52824-10-M12X1.5	058.2843.275	160	14 x 1	17	19	31.5	27.0	36.0	20.5	11.0	20.5	7.0	10.800
SO 52824-18-M22X1.5	058.2843.646	100	24 x 1.5	27	27	44.0	41.5	55.0	31.6	17.0	27.0	12.0	32.800

O-Ring: FPM

Joint: FPM

O-Ring: FPM

d=Rohrassen-ø
 e= kleinste Bohrung
 L= Mass in montiertem Zustand
 *= mit reduziertem Klemmring

d=ø extérieur du tube
 e= ø-min. de passage
 L=après montage
 *=avec bague de serrage de réduction

d=tube outside diameter
 e=minimum bore
 L=installed length
 *=with reduction compression ferrule

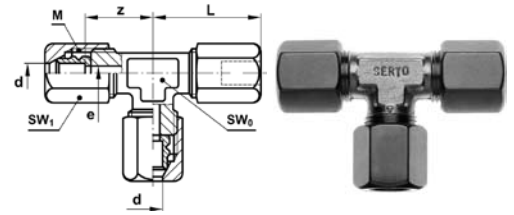
T-Verschraubung
Té
Tee union

SO 53021

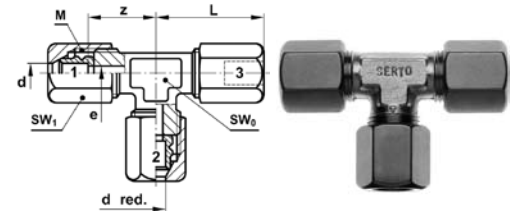
Type -d	Mat.-Nr.	bar	M	SW0	SW1	L	z	e	kg/100
Für metrische Rohre	Pour tubes métriques		For metric tubes						
SO 53021-2	058.3000.020	250	6 x 0.75	9	8	19.0	15.5	2.5	1.730
SO 53021-3	058.3000.030	250	6 x 0.75	9	8	21.0	16.0	2.5	1.850
SO 53021-4	058.3000.040	250	8 x 1	9	10	21.5	16.0	3.5	2.810
SO 53021-5	058.3000.050	250	8 x 1	9	10	21.5	16.0	3.5	2.750
SO 53021-6	058.3000.060	200	10 x 1	9	12	23.5	16.0	4.5	3.990
SO 53021-8	058.3000.080	200	12 x 1	10	14	27.0	18.0	6.5	5.340
SO 53021-10	058.3000.100	160	14 x 1	12	17	31.0	20.5	8.5	8.450
SO 53021-12	058.3000.120	160	16 x 1	14	19	33.5	21.5	9.5	10.700
* SO 53021-14	058.3000.140	100	20 x 1.5	17	24	38.5	24.5	13.0	18.890
SO 53021-15	058.3000.150	100	20 x 1.5	17	24	38.5	24.5	13.0	18.650
* SO 53021-16	058.3000.160	100	24 x 1.5	22	27	42.0	26.5	15.0	25.390
SO 53021-18	058.3000.180	100	24 x 1.5	22	27	42.0	26.5	15.0	24.840
SO 53021-22	058.3000.220	64	28 x 1.5	27	32	50.5	31.0	19.0	38.280
SO 53021-28	058.3000.280	64	36 x 2	36	41	120.0	43.0	25.0	93.700
Für Zollrohre	Pour tubes pouces		For inch tubes						
SO 53021-3,2	058.3000.032	250	6 x 0.75	9	8	21.0	16.0	2.5	1.650
SO 53021-6,35	058.3000.063	200	10 x 1	9	12	23.5	16.0	4.5	3.930
SO 53021-9,52	058.3000.095	160	14 x 1	12	17	31.0	20.5	8.5	8.540
SO 53021-12,7	058.3000.127	100	20 x 1.5	17	24	38.5	24.5	13.0	19.970
* SO 53021-13,5	058.3000.135	100	20 x 1.5	17	24	38.5	24.5	13.0	18.990
* SO 53021-17,2	058.3000.172	100	24 x 1.5	22	27	42.0	26.5	15.0	24.990
* SO 53021-21,3	058.3000.213	64	28 x 1.5	27	32	50.5	31.0	19.0	39.680

T-Verschraubung reduziert
Té réduit
Tee reduction union

SO 53021 RED

Type -d1 -d2 -d3	Mat.-Nr.	bar	M	SW1	SW2	L	z	e	kg/100
SO 53021-2-3-2	058.3004.010	250	6 x 0.75	8	9	19.5	15.5	2.5	1.580
SO 53021-2-3-3	058.3004.012	250	6 x 0.75	8	9	21.0	16.0	2.5	1.600
SO 53021-3-2-2	058.3004.015	250	6 x 0.75	8	9	19.5	15.5	2.5	1.580
* SO 53021-3-5-3	058.3004.020	250	8 x 1	10	9	21.5	16.0	3.5	2.690
* SO 53021-4-6-4	058.3004.025	200	10 x 1	12	9	23.5	16.0	4.0	4.130
* SO 53021-5-3-3	058.3004.030	250	8 x 1	10	9	21.5	16.0	3.5	2.690
* SO 53021-5-3-5	058.3004.034	250	8 x 1	10	9	21.5	16.0	3.5	2.620
* SO 53021-5-5-3	058.3004.038	250	8 x 1	10	9	21.5	16.0	3.5	2.620
* SO 53021-6-4-4	058.3004.046	200	10 x 1	12	9	23.5	16.0	4.0	4.130
* SO 53021-6-4-6	058.3004.049	200	10 x 1	12	9	23.5	16.0	4.0	4.060
* SO 53021-6-6-4	058.3004.053	200	10 x 1	12	9	23.5	16.0	4.0	4.060
* SO 53021-6-8-6	058.3004.058	200	12 x 1	14	10	27.0	18.0	6.0	5.660
* SO 53021-8-6-6	058.3004.091	200	12 x 1	14	10	27.0	18.0	6.0	5.660
* SO 53021-8-6-8	058.3004.093	200	12 x 1	14	10	27.0	18.0	6.0	5.340
* SO 53021-8-8-6	058.3004.100	200	12 x 1	14	10	27.0	18.0	6.0	5.340
* SO 53021-8-10-8	058.3004.104	160	14 x 1	17	12	31.0	20.5	8.0	8.830
* SO 53021-10-8-8	058.3004.151	160	14 x 1	17	12	31.0	20.5	8.0	8.830
* SO 53021-10-8-10	058.3004.153	160	14 x 1	17	12	31.0	20.5	8.0	8.640
* SO 53021-10-10-8	058.3004.161	160	14 x 1	17	12	31.0	20.5	8.0	8.640
* SO 53021-10-12-10	058.3004.165	160	16 x 1	19	14	33.5	21.5	9.5	11.300
* SO 53021-12-10-10	058.3004.220	160	16 x 1	19	14	33.5	21.5	9.5	11.300
* SO 53021-12-10-12	058.3004.222	160	16 x 1	19	14	33.5	21.5	9.5	11.000
* SO 53021-12-12-10	058.3004.232	160	16 x 1	19	14	33.5	21.5	9.5	11.000
* SO 53021-12-15-12	058.3004.254	100	20 x 1.5	24	17	38.5	24.5	12.5	19.770
* SO 53021-15-12-12	058.3004.417	100	20 x 1.5	24	17	38.5	24.5	12.5	19.770
* SO 53021-15-12-15	058.3004.422	100	20 x 1.5	24	17	38.5	24.5	12.5	19.210
* SO 53021-15-15-12	058.3004.435	100	20 x 1.5	24	17	38.5	24.5	12.5	19.210
* SO 53021-15-18-15	058.3004.447	100	24 x 1.5	27	22	42.0	26.5	15.0	26.340
* SO 53021-18-15-15	058.3004.624	100	24 x 1.5	27	22	42.0	26.5	15.0	26.340
* SO 53021-18-15-18	058.3004.628	100	24 x 1.5	27	22	42.0	26.5	15.0	25.590
* SO 53021-18-18-15	058.3004.644	100	24 x 1.5	27	22	42.0	26.5	15.0	25.590
* SO 53021-18-22-18	058.3004.654	64	28 x 1.5	32	27	50.5	31.0	19.0	43.480
* SO 53021-22-18-18	058.3004.854	64	28 x 1.5	32	27	50.5	31.0	19.0	43.480
* SO 53021-22-18-22	058.3004.862	64	28 x 1.5	32	27	50.5	31.0	19.0	40.680
* SO 53021-22-22-18	058.3004.888	64	28 x 1.5	32	27	50.5	31.0	19.0	40.680

Weitere reduzierte T-Verschraubungen, z. B. 16 mm, können mit dem red. Klemmring SO 50001 RED, oder der Reduktion SO 51821, zusammengestellt werden.

D'autres téés réduits, p. ex. 16 mm, peuvent s'obtenir par bague de serrage SO 50001 RED, ou par réduction SO 51821.

Further tee reductions, e. g. 16 mm, can be produced with the reduction ferrule SO 50001 RED, or the reduction union SO 51821.

d=Rohrassen-ø
e= kleinste Bohrung
L= Mass in montiertem Zustand
*=mit reduziertem Klemmring

d=ø extérieur du tube
e= ø-min. de passage
L=après montage
*=avec bague de serrage de réduction

d=tube outside diameter
e=minimum bore
L=installed length
*=with reduction compression ferrule

T-Verschraubung

mit Übergangsnippel

Té

avec adaptateur mâle

Tee union

with male adaptor

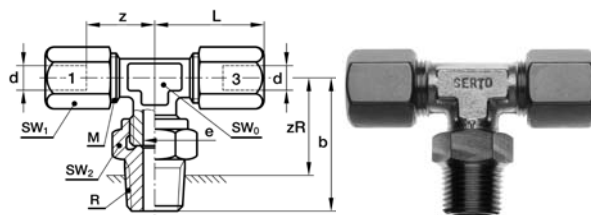
SO 53121

Type	d1	R	d3	Mat.-Nr.	bar	M	SW0	SW1	SW2	L	b	zR	z	e	kg/100	
Für metrische Rohre				Pour tubes métriques				For metric tubes								
R=Rohrgewinde (kegelig)				R=Filetage-gaz BSP (conique)				R=BSP thread (tapered)								
★	SO 53121-3-1/8-3			058.3101.030	250	8 x 1	9	10	10	22.0	26.0	19.5	16.0	3.5	2.870	
	SO 53121-4-1/8-4			058.3101.040	250	8 x 1	9	10	10	22.0	26.0	19.5	16.0	3.5	2.770	
★	SO 53121-4-1/4-4			058.3101.045	250	10 x 1	9	12	14	24.0	30.0	20.5	16.0	4.5	5.090	
	SO 53121-5-1/8-5			058.3101.070	250	8 x 1	9	10	10	22.0	26.0	19.5	16.0	3.5	2.730	
★	SO 53121-5-1/4-5			058.3101.075	250	10 x 1	9	12	14	24.0	30.0	20.5	16.0	4.5	5.010	
	SO 53121-6-1/8-6			058.3101.100	200	10 x 1	9	12	12	24.0	26.0	19.5	16.0	4.5	3.940	
	SO 53121-6-1/4-6			058.3101.110	200	10 x 1	9	12	14	24.0	30.0	20.5	16.0	4.5	4.910	
	SO 53121-8-1/8-8			058.3101.160	200	12 x 1	10	14	14	26.0	28.0	21.5	18.0	6.5	5.270	
	SO 53121-8-1/4-8			058.3101.170	200	12 x 1	10	14	14	26.0	32.0	22.5	18.0	6.5	5.740	
★	SO 53121-8-3/8-8			058.3101.180	160	14 x 1	12	17	17	31.5	34.5	24.5	20.5	8.5	9.330	
★	SO 53121-8-1/2-8			058.3101.190	160	14 x 1	12	17	22	31.5	35.5	22.5	20.5	8.5	11.660	
	SO 53121-10-1/4-10			058.3101.270	160	14 x 1	12	17	17	31.5	34.5	25.0	20.5	8.5	8.240	
	SO 53121-10-3/8-10			058.3101.280	160	14 x 1	12	17	17	31.5	34.5	24.5	20.5	8.5	8.950	
	SO 53121-10-1/2-10			058.3101.290	160	14 x 1	12	17	22	31.5	35.5	22.5	20.5	8.5	11.280	
	SO 53121-12-1/4-12			058.3101.380	160	16 x 1	14	19	19	33.5	36.5	27.0	21.5	9.5	10.460	
	SO 53121-12-3/8-12			058.3101.390	160	16 x 1	14	19	19	33.5	35.5	25.5	21.5	9.5	10.710	
	SO 53121-12-1/2-12			058.3101.400	160	16 x 1	14	19	22	33.5	41.5	26.5	21.5	9.5	13.320	
★	SO 53121-14-1/2-14			058.3101.540	100	20 x 1.5	17	24	24	38.0	42.0	29.0	24.5	13.0	18.850	
	SO 53121-15-1/2-15			058.3101.590	100	20 x 1.5	17	24	24	38.0	42.0	29.0	24.5	13.0	18.610	
★	SO 53121-16-1/2-16			058.3101.630	100	24 x 1.5	22	27	30	42.0	46.0	33.0	26.5	15.0	26.360	
	SO 53121-18-1/2-18			058.3101.730	100	24 x 1.5	22	27	30	42.0	46.0	33.0	26.5	15.0	25.810	
	SO 53121-18-3/4-18			058.3101.740	64	28 x 1.5	27	32	36	49.0	50.0	35.5	30.5	19.0	42.140	
	SO 53121-22-3/4-22			058.3101.830	64	28 x 1.5	27	32	36	49.0	50.0	35.5	30.5	19.0	39.340	
Für Zollrohre				Pour tubes pouces				For inch tubes								
	SO 53121-6,35-1/8-6,35			058.3101.140	200	10 x 1	9	12	12	24.0	26.0	19.5	16.0	4.5	3.900	
	SO 53121-6,35-1/4-6,35			058.3101.145	200	10 x 1	9	12	14	24.0	30.0	20.5	16.0	4.5	4.870	
	SO 53121-9,52-1/4-9,52			058.3101.210	160	14 x 1	12	17	17	31.5	34.5	25.0	20.5	8.5	8.300	
	SO 53121-9,52-3/8-9,52			058.3101.215	160	14 x 1	12	17	17	31.5	34.5	24.5	20.5	8.5	9.010	
	SO 53121-9,52-1/2-9,52			058.3101.220	160	14 x 1	12	17	22	31.5	35.5	22.5	20.5	8.5	11.340	
	SO 53121-12,7-1/2-12,7			058.3101.460	100	20 x 1.5	17	24	24	38.0	42.0	29.0	24.5	13.0	19.490	
★	SO 53121-13,5-1/2-13,5			058.3101.514	100	20 x 1.5	17	24	24	38.0	42.0	29.0	24.5	13.0	18.950	
★	SO 53121-17,2-1/2-17,2			058.3101.700	100	24 x 1.5	22	27	30	42.0	46.0	33.0	26.5	15.0	26.060	
★	SO 53121-21,3-3/4-21,3			058.3101.800	64	28 x 1.5	27	32	36	49.0	50.0	35.5	30.5	19.0	40.740	

Der Übergangsnippel SO 50040 kann an jedes SERTO-Formteil anstelle des Armaturenanschlusses SO 50021 mit dem passenden Gewinde aufgeschraubt werden. In Verbindung mit den Formteilen ist der Übergangsnippel SO 50040 nur lose aufgeschraubt und muss bei der Montage angezogen werden. Dichtungsprinzip siehe SO 50040. Die Bestellnummer für ein T-Stück mit aufgeschraubtem Übergangsnippel SO 50040 lautet SO 53121-d-R-d.

L'adaptateur mâle SO 50040 peut être monté sur toutes les pièces de forme SERTO avec le filetage correspondant, au lieu et place de l'écrou SO 50021. En cas de livraison avec des pièces SERTO, l'adaptateur SO 50040 n'est que très légèrement vissé et doit être resserré lors du montage. Principe de l'étanchéité et filetage voir SO 50040. No de commande pour un Té avec adaptateur SO 50040 = SO 53121-d-R-d.

The male adaptor SO 50040 can be fitted to any SERTO forged body in place of the nut connection SO 50021 with the relevant thread. Combinations are supplied with the male adaptor SO 50040 screwed only loosely on the body. It must be tightened for installation. See SO 50040 for sealing principle. The order No. for a Tee union complete with male adaptor SO 50040 is SO 53121-d-R-d.

d=Rohrassen-ø
e=kleinste Bohrung
L=Mass in montiertem Zustand
*=mit reduziertem Klemmring

d=ø extérieur du tube
e=ø-min. de passage
L=après montage
*=avec bague de serrage de réduction

d=tube outside diameter
e=minimum bore
L=installed length
*=with reduction compression ferrule

T-Verschraubung

mit Übergangsnippel NPT

Té

avec adaptateur mâle NPT

Tee union

with male adaptor NPT

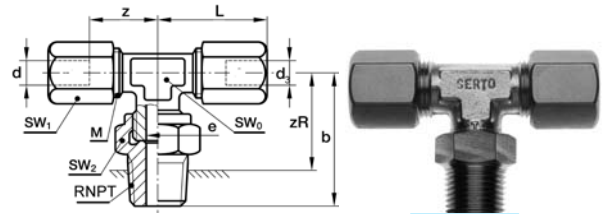

SO 53121 NPT

Type -d1 -RNPT -d3	Mat.-Nr.	bar	M	SW0	SW1	SW2	L	b	zR	z	e	kg/100
Für metrische Rohre RNPT=NPT Gewinde	Pour tubes métriques RNPT=Filetage NPT	For metric tubes RNPT=NPT thread										
★ SO 53121-3-1/8 NPT-3	058.3102.030	250	8 x 1	9	10	10	22.0	28.0	21.5	16.0	3.5	2.990
SO 53121-4-1/8 NPT-4	058.3102.040	250	8 x 1	9	10	10	22.0	28.0	21.5	16.0	3.5	2.890
★ SO 53121-4-1/4 NPT-4	058.3102.045	200	10 x 1	9	12	14	23.5	32.0	22.0	16.0	4.5	5.260
SO 53121-5-1/8 NPT-5	058.3102.070	250	8 x 1	9	10	10	22.0	28.0	21.5	16.0	3.5	2.850
★ SO 53121-5-1/4 NPT-5	058.3102.075	200	10 x 1	9	12	14	23.5	32.0	22.0	16.0	4.5	5.180
SO 53121-6-1/8 NPT-6	058.3102.100	200	10 x 1	9	12	12	23.5	28.0	21.5	16.0	4.5	4.050
SO 53121-6-1/4 NPT-6	058.3102.110	200	10 x 1	9	12	14	23.5	32.0	22.0	16.0	4.5	5.080
SO 53121-8-1/4 NPT-8	058.3102.170	200	12 x 1	10	14	14	26.5	34.0	24.0	18.0	6.5	5.900
SO 53121-10-1/4 NPT-10	058.3102.270	160	14 x 1	12	17	17	31.0	36.5	26.5	20.5	8.5	8.350
★ SO 53121-10-1/2 NPT-10	058.3102.290	160	16 x 1	14	19	22	33.5	42.5	29.0	21.5	9.5	14.220
SO 53121-12-1/4 NPT-12	058.3102.380	160	16 x 1	14	19	19	33.5	38.5	27.5	21.5	9.5	10.540
SO 53121-12-3/8 NPT-12	058.3102.390	160	16 x 1	14	19	19	33.5	38.5	27.0	21.5	9.5	10.750
SO 53121-12-1/2 NPT-12	058.3102.400	160	16 x 1	14	19	22	33.5	42.5	29.0	21.5	9.5	13.820
★ SO 53121-14-1/2 NPT-14	058.3102.540	100	20 x 1.5	17	24	24	38.0	45.0	31.5	24.5	13.0	19.530
SO 53121-15-1/2 NPT-15	058.3102.590	100	20 x 1.5	17	24	24	38.0	45.0	31.5	24.5	13.0	18.950

Für Zollrohre	Pour tubes pouces	For inch tubes										
SO 53121-6,35-1/8 NPT-6,35	058.3102.140	200	10 x 1	9	12	12	23.5	28.0	21.5	16.0	4.5	4.010
SO 53121-6,35-1/4 NPT-6,35	058.3102.145	200	10 x 1	9	12	14	23.5	32.0	22.0	16.0	4.5	5.040
SO 53121-9,52-1/4 NPT-9,52	058.3102.210	160	14 x 1	12	17	17	31.0	36.5	26.5	20.5	8.5	8.410
SO 53121-12,7-1/2 NPT-12,7	058.3102.460	100	20 x 1.5	17	24	24	38.0	45.0	31.5	24.5	13.0	19.830
★ SO 53121-13,5-1/2 NPT-13,5	058.3102.514	100	20 x 1.5	17	24	24	38.0	45.0	31.5	24.5	13.0	19.730

T-Verschraubung METR

mit Übergangsnippel

Té METR

avec adaptateur mâle

Tee union METR

with male adaptor

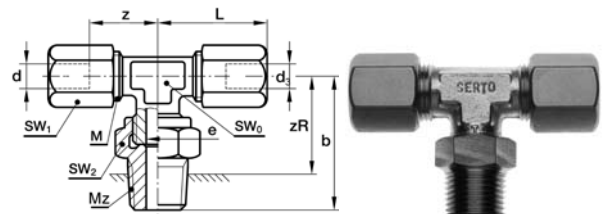

SO 53121 METR

Type -d -Mz -d3	Mat.-Nr.	bar	M	SW0	SW1	SW2	L	b	zR	z	e	kg/100
Für metrische Rohre Mz=metrisches Gewinde (zylindrisch)	Pour tubes métriques Mz=Filetage métrique (cylindrique)	For metric tubes Mz=Metric thread (straight)										
★ SO 53121-3-M6X0,75-3	058.3143.055	250	8 x 1	9	10	10	22.0	24.0	19.5	16.0	3.5	2.610
★ SO 53121-3-M8X1-3	058.3143.060	250	8 x 1	9	10	10	22.0	26.0	19.5	16.0	3.5	2.720
SO 53121-4-M6X0,75-4	058.3143.085	250	8 x 1	9	10	10	22.0	24.0	19.0	16.0	3.5	2.510
SO 53121-4-M8X1-4	058.3143.090	250	8 x 1	9	10	10	22.0	26.0	19.0	16.0	3.5	2.620
SO 53121-5-M6X0,75-5	058.3143.115	250	8 x 1	9	10	10	22.0	24.0	19.5	16.0	3.5	2.470
SO 53121-5-M8X1-5	058.3143.125	250	8 x 1	9	10	10	22.0	26.0	19.0	16.0	3.5	2.580

d=Rohrassen-ø
e=kleinste Bohrung
L=Mass in montiertem Zustand
*=mit reduziertem Klemmring

d=ø extérieur du tube
e=ø-min. de passage
L=après montage
*=avec bague de serrage de réduction

d=tube outside diameter
e=minimum bore
L=installed length
*=with reduction compression ferrule

T-Verschraubung

mit Übergangsmuffe

Té

avec adaptateur femelle

Tee union

with female adaptor

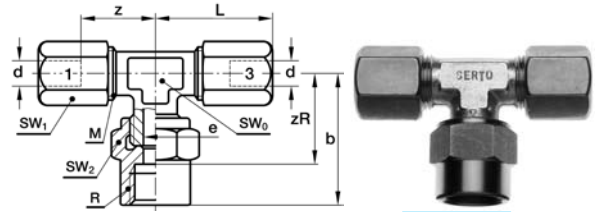
SO 53221

Type-d1-R-d3	Mat.-Nr.	bar	M	SW0	SW1	SW2	L	b	zR	z	e	kg/100
Für metrische Rohre	Pour tubes métriques	For metric tubes										
G=Rohrgewinde (zylindrisch)	G=Filetage-gaz BSP (cylindrique)	G=BSP thread (straight)										
* SO 53221-4-1/8-4	058.3201.040	200	10 x 1	9	12	14	23.5	29.0	19.0	16.0	4.5	4.820
* SO 53221-5-1/8-5	058.3201.070	200	10 x 1	9	12	14	23.5	29.0	19.0	16.0	4.5	4.780
SO 53221-6-1/8-6	058.3201.100	200	10 x 1	9	12	14	23.5	29.0	19.0	16.0	4.5	4.680
SO 53221-6-1/4-6	058.3201.110	200	12 x 1	10	14	17	26.5	33.0	22.0	18.0	6.5	6.760
SO 53221-8-1/8-8	058.3201.160	200	12 x 1	10	14	17	26.5	31.0	21.0	18.0	6.5	6.850
SO 53221-8-1/4-8	058.3201.170	200	12 x 1	10	14	17	26.5	33.0	22.0	18.0	6.5	6.440
SO 53221-8-3/8-8	058.3201.180	160	14 x 1	12	17	17	31.5	35.5	23.5	20.5	8.5	8.730
SO 53221-10-1/4-10	058.3201.270	160	14 x 1	12	17	17	31.5	34.5	23.5	20.5	8.5	8.540
SO 53221-10-3/8-10	058.3201.280	160	14 x 1	12	17	22	31.5	35.5	23.5	20.5	8.5	10.720
SO 53221-12-3/8-12	058.3201.390	160	16 x 1	14	19	22	33.5	36.5	24.5	21.5	9.5	12.210
* SO 53221-12-1/2-12	058.3201.400	100	20 x 1.5	17	24	27	38.0	42.0	28.0	24.5	13.0	22.160
* SO 53221-14-1/2-14	058.3201.540	100	20 x 1.5	17	24	27	38.0	42.0	28.0	24.5	13.0	21.520
SO 53221-15-1/2-15	058.3201.590	100	20 x 1.5	17	24	27	38.0	42.0	28.0	24.5	13.0	21.040
* SO 53221-16-1/2-16	058.3201.630	100	24 x 1.5	22	27	30	42.0	45.0	31.0	26.5	15.0	29.700
SO 53221-18-1/2-18	058.3201.730	100	24 x 1.5	22	27	30	42.0	45.0	31.0	26.5	15.0	28.600
Für Zollrohre	Pour tubes pouces	For inch tubes										
SO 53221-6,35-1/8-6,35	058.3201.140	200	10 x 1	9	12	14	23.5	29.0	19.0	16.0	4.5	4.640
SO 53221-9,52-1/4-9,52	058.3201.210	160	14 x 1	12	17	17	31.5	34.5	23.5	20.5	8.5	8.600
SO 53221-9,52-3/8-9,52	058.3201.215	160	14 x 1	12	17	22	31.5	35.5	23.5	20.5	8.5	10.780
SO 53221-12,7-1/2-12,7	058.3201.460	100	20 x 1.5	17	24	27	38.0	42.0	28.0	24.5	13.0	21.920
* SO 53221-13,5-1/2-13,5	058.3201.514	100	20 x 1.5	17	24	27	38.0	42.0	28.0	24.5	13.0	21.820
* SO 53221-17,2-1/2-17,2	058.3201.700	100	24 x 1.5	22	27	30	42.0	45.0	31.0	26.5	15.0	29.100

Die Übergangsmuffe SO 50030 kann an jedes SERTO-Formteil anstelle des Armaturenanschlusses SO 50021 mit dem passenden Gewinde aufgeschraubt werden. In Verbindung mit den Formteilen ist die Übergangsmuffe SO 50030 nur lose aufgeschraubt und muss bei der Montage angezogen werden. Dichtungsprinzip siehe SO 50030.

Die Bestellnummer für ein T-Stück mit aufgeschraubter Übergangsmuffe SO 50030 lautet SO 53221-d-G1-d.

L'adaptateur femelle SO 50030 peut être monté sur toutes les pièces de forme SERTO avec le filetage correspondant, au lieu et place de l'écrou SO 50021. En cas de livraison avec des pièces SERTO, l'adaptateur SO 50030 n'est que très légèrement vissé et doit être resserré lors du montage. Principe de l'étanchéité et filetage voir SO 50030.

No de commande pour un Té avec adaptateur SO 50030 = SO 03221-d-G1-d.

The female adaptor SO 50030 can be fitted to any SERTO forged body in place of the nut connection SO 50021 with the relevant thread. Combinations are supplied with the female adaptor SO 50030 screwed only loosely on the body. It must be tightened for installation. See SO 50030 for sealing principle. The order No. for a Tee union complete with female adaptor SO 50030 is SO 53221-d-G1-d.

d=Rohrassen-ø
e=kleinste Bohrung
L=Mass in montiertem Zustand
*=mit reduziertem Klemmring

d=ø extérieur du tube
e=ø-min. de passage
L=après montage
*=avec bague de serrage de réduction

d=tube outside diameter
e=minimum bore
L=installed length
*=with reduction compression ferrule

Einstellbare T-Verschraubung

Té orientable

Adjustable tee union

SO 53621 T

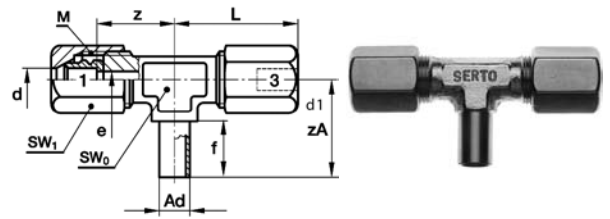

Type -d1 -Ad -d3	Mat.-Nr.	bar	M	SW0	SW1	L	f	z	zA	e	kg/100	
Für metrische Rohre	Pour tubes métriques			For metric tubes								
* SO 53621-4-A6-4	058.3600.045	200	10 x 1	9	12	23.5	12.5	16.0	18.0	4.0	3.170	
* SO 53621-5-A6-5	058.3600.053	200	10 x 1	9	12	23.5	12.5	16.0	18.0	4.0	3.130	
SO 53621-6-A6-6	058.3600.060	200	10 x 1	9	12	23.5	12.5	16.0	18.0	4.0	3.030	
* SO 53621-6-A8-6	058.3600.063	200	12 x 1	10	14	26.5	15.0	18.0	23.0	6.0	4.420	
SO 53621-8-A8-8	058.3600.080	200	12 x 1	10	14	26.5	15.0	18.0	23.0	6.0	4.020	
* SO 53621-8-A10-8	058.3600.083	160	14 x 1	12	17	31.5	17.0	20.5	25.5	7.5	6.760	
SO 53621-10-A10-10	058.3600.100	160	14 x 1	12	17	31.5	17.0	20.5	25.5	7.5	6.420	
Für Zollrohre	Pour tubes pouces			For inch tubes								
SO 53621-6,35-A6-6,35	058.3600.067	200	10 x 1	9	12	23.5	12.5	16.0	18.0	4.0	2.990	
* SO 53621-6,35-A8-6,35	058.3600.070	200	12 x 1	10	14	26.5	15.0	18.0	23.0	6.0	4.380	

Anwendungsbeispiele:

Exemples d'utilisation:

Sample combinations:

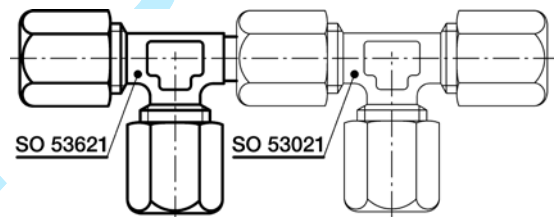
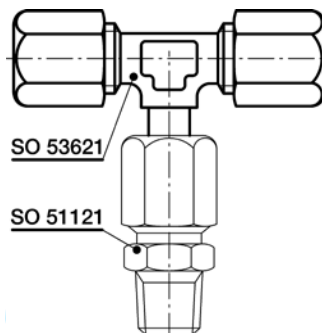
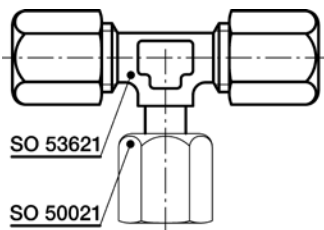

Das Einstell-T SO 53621 ergibt im Zusammenhang mit unserem Armaturenanschluss SO 50021 eine einstellbare T-Kombination. Gegenüber dem Einschraub-T lässt sich diese Kombination einfacher einstellen, da Einschrauben und Ausrichten getrennt voneinander vorgenommen werden.

L'assemblage du SO 53621 et d'un écrou SO 50021 donne un té orientable. Par rapport à un Té mâle, cette combinaison permet un positionnement plus facile. L'emboîtement et l'alignement se font séparément.

In combination with our nut connection SO 50021, the adjustable tee union SO 53621 forms an adjustable female adaptor tee union. In contrast to the simple male adaptor Tee union, this combination is easier to adjust, since screw on and aligning are performed separately.

d=Rohrassens-ø
 Ad=Aussen-ø der Drehung
 e=kleinste Bohrung
 L=Mass in montiertem Zustand
 *=mit reduziertem Klemmring

d=ø extérieur du tube
 Ad=ø extérieur de la portée cylindrique
 e=ø-min. de passage
 L=après montage
 *=avec bague de serrage de réduction

d=tube outside diameter
 Ad=outside diameter of cyl. stub
 e=minimum bore
 L=installed length
 *=with reduction compression ferrule

Einstellbare L-Verschraubung

Té orientable

Adjustable tee union

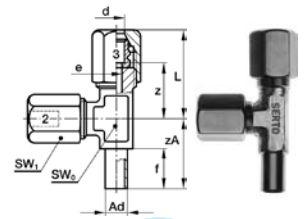

SO 53621 L

Type -Ad -d2 -d3	Mat.-Nr.	bar	M	SW0	SW1	L	f	z	zA	e	kg/100
Für metrische Rohre	Pour tubes métriques	For metric tubes									
* SO 53621-A6-4-4	058.3610.045	200	10x1	9	12	23.5	12.0	16.0	18.0	4.0	3.170
* SO 53621-A6-5-5	058.3610.053	200	10x1	9	12	23.5	12.0	16.0	18.0	4.0	3.130
SO 53621-A6-6-6	058.3610.060	200	10x1	9	12	23.5	12.0	16.0	18.0	4.0	3.030
* SO 53621-A8-6-6	058.3610.063	200	12x1	9	14	23.5	12.0	18.0	17.5	6.0	4.420
SO 53621-A8-8-8	058.3610.080	200	14x1	10	14	26.0	14.0	18.0	23.0	6.0	4.020
* SO 53621-A10-8-8	058.3610.083	160	14x1	12	17	32.0	16.0	20.5	25.5	7.5	6.760
SO 53621-A10-10-10	058.3610.100	160	14x1	12	17	32.0	16.0	20.5	25.5	7.5	6.760
Für Zollrohre	Pour tubes pouces	For inch tubes									
SO 53621-A6-6,35-6,35	058.3610.061	200	10x1	9	12	23.5	11.0	16.0	18.0	4.0	2.990
* SO 53621-A8-6,35-6,35	058.3610.068	200	12x1	10	14	26.0	12.0	18.0	21.5	6.0	4.380

d=Rohraussen-ø
 Ad=Aussen-ø der Andrehung
 e=kleinste Bohrung
 L=Mass in montiertem Zustand
 *=mit reduziertem Klemmring

d=ø extérieur du tube
 Ad=ø extérieur de la portée cylindrique
 e=ø-min. de passage
 L=après montage
 *=avec bague de serrage de réduction

d=tube outside diameter
 Ad=outside diameter of cyl. stub
 e=minimum bore
 L=installed length
 *=with reduction compression ferrule

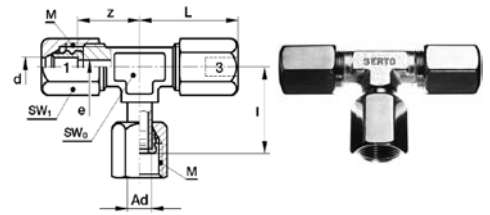
Einstellbare T-Verschraubung vormontiert
Té orientable montée
Adjustable tee assembly

SO 53625 T

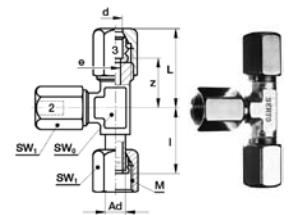
Type -d1 -Ad -d3	Mat.-Nr.	bar	M	SW0	SW1	L	I	z	e	kg/100
Für metrische Rohre	Pour tubes métriques	For metric tubes								
* SO 53625-4-A6-4	058.3620.045	200	10 x 1	9	12	23.5	19,2	16.0	4.0	3.710
* SO 53625-5-A6-5	058.3620.053	200	10 x 1	9	12	23.5	19,2	16.0	4.0	3.650
SO 53625-6-A6-6	058.3620.060	200	10 x 1	9	12	23.5	19,2	16.0	4.0	3.820
* SO 53625-6-A8-6	058.3620.063	200	12 x 1	10	14	26.0	24,2	18.0	6.0	5.470
SO 53625-8-A8-8	058.3620.080	200	12 x 1	10	14	26.0	24,2	18.0	6.0	5.070
* SO 53625-8-A10-8	058.3620.083	160	14 x 1	12	17	30.5	27,2	20.5	7.5	8.550
SO 53625-10-A10-10	058.3620.100	160	14 x 1	12	17	30.5	27,2	20.5	7.5	8.200
Für Zollrohre	Pour tubes pouces	For inch tubes								
SO 53625-6.35-A6-6.35	058.3620.067	200	10 x 1	9	12	23.5	18,7	16.0	4.0	3.780
* SO 53625-6.35-A8-6.35	058.3620.070	200	12 x 1	10	14	26.0	22,2	18.0	6.0	4.430

Einstellbare L-Verschraubung vormontiert
L orientable montée
Adjustable L assembly

SO 53625 L

Type -Ad -d2 -d3	Mat.-Nr.	bar	M	SW0	SW1	L	I	z	e	kg/100
Für metrische Rohre	Pour tubes métriques	For metric tubes								
* SO 53625-A6-4-4	058.3630.045	200	10 x 1	9	12	23.5	19,2	16.0	4.0	3.710
* SO 53625-A6-5-5	058.3630.053	200	10 x 1	9	12	23.5	19,2	16.0	4.0	3.650
SO 53625-A6-6-6	058.3630.060	200	10 x 1	9	12	23.5	19,2	16.0	4.0	3.820
* SO 53625-A8-6-6	058.3630.063	200	12 x 1	10	14	26.0	24,2	18.0	6.0	5.470
SO 53625-A8-8-8	058.3630.080	200	12 x 1	10	14	26.0	24,2	18.0	6.0	5.070
* SO 53625-A10-8-8	058.3630.083	160	14 x 1	12	17	30.5	27,2	20.5	7.5	8.550
SO 53625-A10-10-10	058.3630.100	160	14 x 1	12	17	30.5	27,2	20.5	7.5	8.200
Für Zollrohre	Pour tubes pouces	For inch tubes								
SO 53625-A6-6.35-6.35	058.3630.061	200	10 x 1	9	12	23.5	18,7	16.0	4.0	3.780
* SO 53625-A8-6.35-6.35	058.3630.068	200	12 x 1	10	14	26.0	22,2	18.0	6.0	4.430

M=Anschlussgewinde
 I=Einbaulänge
 e=kleinste Bohrung
 L=Mass in montiertem Zustand
 *=mit reduziertem Klemmring

M=filetage
 I=longueur encastrée
 e=ø-min. de passage
 L=après montage
 *=avec bague de serrage de réduction

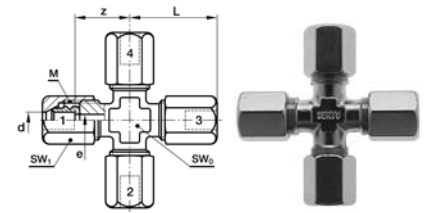
M=thread
 I=fitted length
 e=minimum bore
 L=installed length
 *=with reduction compression ferrule

Kreuzverschraubung
Croix
Cross union

SO 54021

Type-d	Mat.-Nr.	bar	M	SW0	SW1	L	z	e	kg/100
Für metrische Rohre	Pour tubes métriques	For metric tubes							
* SO 54021-4	058.4000.040	200	10 x 1	12	12	25.0	17.5	4.5	5.600
* SO 54021-5	058.4000.050	200	10 x 1	12	12	25.0	17.5	4.5	5.550
SO 54021-6	058.4000.060	200	10 x 1	12	12	25.0	17.5	4.5	5.500
SO 54021-8	058.4000.080	200	12 x 1	12	14	27.5	19.0	6.5	7.400
SO 54021-10	058.4000.100	160	14 x 1	17	17	33.5	23.0	8.5	11.400
SO 54021-12	058.4000.120	160	16 x 1	17	19	37.0	25.0	9.5	13.900
* SO 54021-14	058.4000.140	100	20 x 1.5	19	24	40.0	26.5	13.0	25.300
SO 54021-15	058.4000.150	100	20 x 1.5	19	24	40.0	26.5	13.0	24.500
Für Zollrohre	Pour tubes pouces	For inch tubes							
SO 54021-6.35	058.4000.063	200	10 x 1	12	12	25.0	17.5	4.5	5.500
SO 54021-9.52	058.4000.095	160	14 x 1	17	17	33.5	23.0	8.5	11.600
SO 54021-12.7	058.4000.127	100	20 x 1.5	19	24	40.0	26.5	13.0	28.000
* SO 54021-13.5	058.4000.135	100	20 x 1.5	19	24	40.0	26.5	13.0	25.800

d=Rohraussen-ø
 e= kleinste Bohrung
 L= Mass in montiertem Zustand
 *=mit reduzierten Klemmring

d=ø extérieur du tube
 e= ø-min. de passage
 L=après montage
 *=avec bague de serrage de réduction

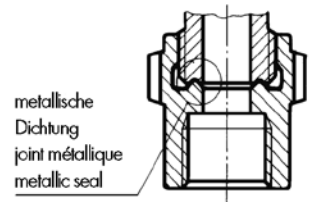
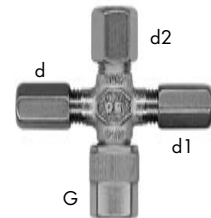
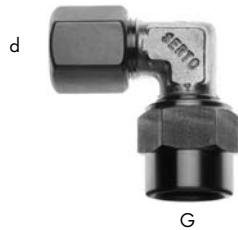
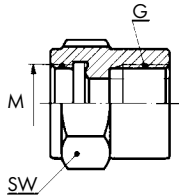
d=tube outside diameter
 e=minimum bore
 L=installed length
 *=with compression ferrule

Anschlussvarianten mit Übergangsmuffe
Variantes de raccordement avec adaptateur femelle
Connections with female adaptor

SO 50030
SO 5221
SO 5321
SO 5421

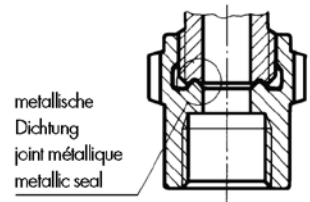
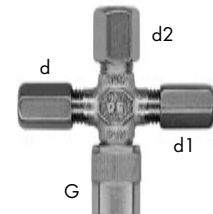
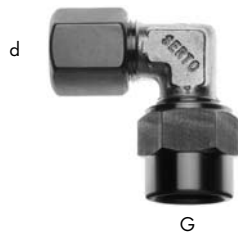
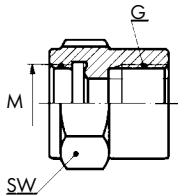
M	SW	-G	-d	-G	-d1	-G	-d3	-d	-G	-d1	-d2
M 10 x 1	14	-1/8	-4	-1/8	-4	-1/8	-4	-4	-1/8	-4	-4
M 10 x 1	17	-1/4	-4	-1/4	-4	-1/4	-4	-4	-1/4	-4	-4
M 10 x 1	22	-3/8	-4	-3/8	-4	-3/8	-4	-4	-3/8	-4	-4
M 10 x 1	27	-1/2	-4	-1/2	-4	-1/2	-4	-4	-1/2	-4	-4
M 10 x 1	14	-1/8	-5	-1/8	-5	-1/8	-5	-5	-1/8	-5	-5
M 10 x 1	17	-1/4	-5	-1/4	-5	-1/4	-5	-5	-1/4	-5	-5
M 10 x 1	22	-3/8	-5	-3/8	-5	-3/8	-5	-5	-3/8	-5	-5
M 10 x 1	27	-1/2	-5	-1/2	-5	-1/2	-5	-5	-1/2	-5	-5
M 10 x 1	14	-1/8	-6	-1/8	-6	-1/8	-6	-6	-1/8	-6	-6
M 10 x 1	17	-1/4	-6	-1/4	-6	-1/4	-6	-6	-1/4	-6	-6
M 10 x 1	22	-3/8	-6	-3/8	-6	-3/8	-6	-6	-3/8	-6	-6
M 10 x 1	27	-1/2	-6	-1/2	-6	-1/2	-6	-6	-1/2	-6	-6
M 12 x 1	17	-1/8	-8	-1/8	-8	-1/8	-8	-8	-1/8	-8	-8
M 12 x 1	17	-1/4	-8	-1/4	-8	-1/4	-8	-8	-1/4	-8	-8
M 12 x 1	22	-3/8	-8	-3/8	-8	-3/8	-8	-8	-3/8	-8	-8
M 12 x 1	27	-1/2	-8	-1/2	-8	-1/2	-8	-8	-1/2	-8	-8
M 14 x 1	17	-1/4	-10	-1/4	-10	-1/4	-10	-10	-1/4	-10	-10
M 14 x 1	22	-3/8	-10	-3/8	-10	-3/8	-10	-10	-3/8	-10	-10
M 14 x 1	27	-1/2	-10	-1/2	-10	-1/2	-10	-10	-1/2	-10	-10
M 16 x 1	19	-1/4	-12	-1/4	-12	-1/4	-12	-12	-1/4	-12	-12
M 16 x 1	22	-3/8	-12	-3/8	-12	-3/8	-12	-12	-3/8	-12	-12
M 16 x 1	27	-1/2	-12	-1/2	-12	-1/2	-12	-12	-1/2	-12	-12
M 20 x 1,5	24	-1/4	-14	-1/4	-14	-1/4	-14	-14	-1/4	-14	-14
M 20 x 1,5	24	-3/8	-14	-3/8	-14	-3/8	-14	-14	-3/8	-14	-14
M 20 x 1,5	27	-1/2	-14	-1/2	-14	-1/2	-14	-14	-1/2	-14	-14
M 20 x 1,5	32	-3/4	-14	-3/4	-14	-3/4	-14	-14	-3/4	-14	-14
M 20 x 1,5	24	-1/4	-15	-1/4	-15	-1/4	-15	-15	-1/4	-15	-15
M 20 x 1,5	24	-3/8	-15	-3/8	-15	-3/8	-15	-15	-3/8	-15	-15
M 20 x 1,5	27	-1/2	-15	-1/2	-15	-1/2	-15	-15	-1/2	-15	-15
M 20 x 1,5	32	-3/4	-15	-3/4	-15	-3/4	-15	-15	-3/4	-15	-15

Anschlussvarianten mit Übergangsmuffe
Variantes de raccordement avec adaptateur femelle
Connections with female adaptor

SO 50030
SO 52221
SO 53221
SO 54221

M	SW	-G	-d	-G	-d1	-G	-d3	-d	-G	-d1	-d2
M 24 x 1,5	30	-1/2	-16	-1/2	-16	-1/2	-16				
M 24 x 1,5	30	-1/2	-18	-1/2	-18	-1/2	-18				
M 10 x 1	14	-1/8	-6,35	-1/8	-6,35	-1/8	-6,35	-6,35	-1/8	-6,35	-6,35
M 10 x 1	14	-1/4	-6,35	-1/4	-6,35	-1/4	-6,35	-6,35	-1/4	-6,35	-6,35
M 10 x 1	14	-3/8	-6,35	-3/8	-6,35	-3/8	-6,35	-6,35	-3/8	-6,35	-6,35
M 10 x 1	14	-1/2	-6,35	-1/2	-6,35	-1/2	-6,35	-6,35	-1/2	-6,35	-6,35
M 14 x 1	17	-1/4	-9,52	-1/4	-9,52	-1/4	-9,52	-9,52	-1/4	-9,52	-9,52
M 14 x 1	22	-3/8	-9,52	-3/8	-9,52	-3/8	-9,52	-9,52	-3/8	-9,52	-9,52
M 14 x 1	27	-1/2	-9,52	-1/2	-9,52	-1/2	-9,52	-9,52	-1/2	-9,52	-9,52
M 20 x 1,5	24	-1/4	-12,7	-1/4	-12,7	-1/4	-12,7	-12,7	-1/4	-12,7	-12,7
M 20 x 1,5	24	-3/8	-12,7	-3/8	-12,7	-3/8	-12,7	-12,7	-3/8	-12,7	-12,7
M 20 x 1,5	27	-1/2	-12,7	-1/2	-12,7	-1/2	-12,7	-12,7	-1/2	-12,7	-12,7
M 20 x 1,5	24	-1/4	-13,5	-1/4				-13,5	-1/4	-13,5	-13,5
M 20 x 1,5	24	-3/8	-13,5	-3/8				-13,5	-3/8	-13,5	-13,5
M 20 x 1,5	27	-1/2	-13,5	-1/2	-13,5	-1/2	-13,5	-13,5	-1/2	-13,5	-13,5
M 24 x 1,5	30	-1/2	-17,2	-1/2	-17,2	-1/2	-17,2				

Anschlussvarianten mit Übergangsnippel

Variantes de raccordement avec adaptateur mâle

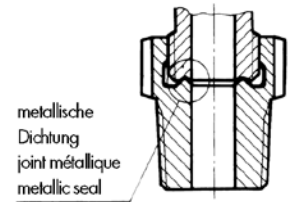
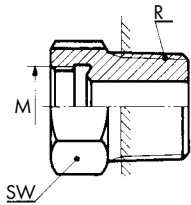
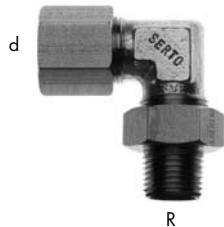
Connections with male adaptor

S0 50040

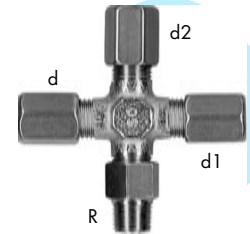
S0 52121

S0 53121

S0 54121

M	SW	-R	-d	-R	-d1	-R	-d3	-d	-R	-d1	-d2
M 8 x 1	10	-1/8			-3	-1/8	-3				
M 8 x 1	10	-1/8			-4	-1/8	-4				
M 8 x 1	10	-1/8			-5	-1/8	-5				
M 10 x 1	12	-1/8						-4	-1/8	-4	-4
M 10 x 1	14	-1/4			-4	-1/4	-4	-4	-1/4	-4	-4
M 10 x 1	17	-3/8						-4	-3/8	-4	-4
M 10 x 1	22	-1/2						-4	-1/2	-4	-4
M 10 x 1	12	-1/8						-5	-1/8	-5	-5
M 10 x 1	14	-1/4			-5	-1/4	-5	-5	-1/4	-5	-5
M 10 x 1	17	-3/8						-5	-3/8	-5	-5
M 10 x 1	22	-1/2						-5	-1/2	-5	-5
M 10 x 1	12	-1/8			-6	-1/8	-6	-6	-1/8	-6	-6
M 10 x 1	14	-1/4			-6	-1/4	-6	-6	-1/4	-6	-6
M 10 x 1	17	-3/8			-6	-3/8	-6	-6	-3/8	-6	-6
M 10 x 1	22	-1/2			-6	-1/2	-6	-6	-1/2	-6	-6
M 12 x 1	14	-1/8	-8	-1/8	-8	-1/8	-8	-8	-1/8	-8	-8
M 12 x 1	14	-1/4			-8	-1/4	-8	-8	-1/4	-8	-8
M 12 x 1	17	-3/8			-8	-3/8	-8	-8	-3/8	-8	-8
M 12 x 1	22	-1/2			-8	-1/2	-8	-8	-1/2	-8	-8
M 14 x 1	17	-1/8						-10	-1/8	-10	-10
M 14 x 1	17	-1/4			-10	-1/4	-10	-10	-1/4	-10	-10
M 14 x 1	17	-3/8			-10	-3/8	-10	-10	-3/8	-10	-10
M 14 x 1	22	-1/2	-10	-1/2	-10	-1/2	-10	-10	-1/2	-10	-10
-											
M 16 x 1	19	-1/4			-12	-1/4	-12	-12	-1/4	-12	-12
M 16 x 1	19	-3/8			-12	-3/8	-12	-12	-3/8	-12	-12
M 16 x 1	22	-1/2			-12	-1/2	-12	-12	-1/2	-12	-12
M 20 x 1,5	24	-3/8						-14	-3/8	-14	-14
M 20 x 1,5	24	-1/2			-14	-1/2	-14	-14	-1/2	-14	-14
M 20 x 1,5	27	-3/4						-14	-3/4	-14	-14
M 20 x 1,5	24	-3/8						-15	-3/8	-15	-15
M 20 x 1,5	24	-1/2			-15	-1/2	-15	-15	-1/2	-15	-15
M 20 x 1,5	27	-3/4						-15	-3/4	-15	-15
M 24 x 1,5	30	-1/2			-16	-1/2	-16				
			-16	-1/2	-18	-1/2	-18				
M 24 x 1,5	30	-1/2	-18	-1/2							
			-18	-3/4							
M 28 x 1,5	36	-3/4			-18	-3/4	-18				
M 28 x 1,5	36	-3/4	-22	-3/4	-22	-3/4	-22				

Anschlussvarianten mit Übergangsnippel

Variantes de raccordement avec adaptateur mâle

Connections with male adaptor

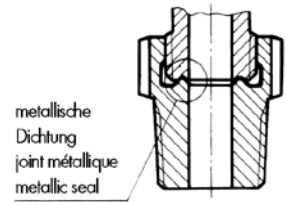
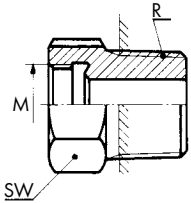
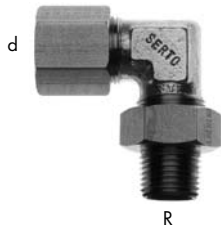
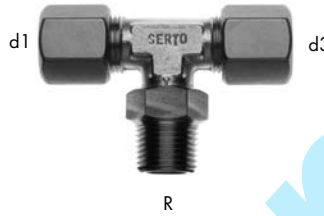
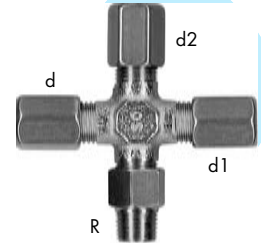
S0 50040

S0 52121

S0 53121

S0 54121

M	SW	-R	-d	-R	-d1	-R	-d3	-d	-R	-d1	-d2
Metrisches Feingewinde zylindrisch / Filetage métrique / Straight metric thread											
M 8 x 1	10	M6 x 0,75	-3	M6 x 0,75	-3	M6 x 0,75					
M 8 x 1	10	M8 x 1	-3	M8 x 1	-3	M8 x 1					
M 8 x 1	10	M6 x 0,75	-4	M6 x 0,75	-4	M6 x 0,75		-4	M6 x 0,75	-4	-4
M 8 x 1	10	M8 x 1	-4	M8 x 1	-4	M8 x 1		-4	M8 x 1	-4	-4
M 8 x 1	10	M6 x 0,75	-5	M6 x 0,75	-5	M6 x 0,75		-5	M6 x 0,75	-5	-5
M 8 x 1	10	M8 x 1	-5	M8 x 1	-5	M8 x 1		-5	M8 x 1	-5	-5

M	SW	-d	-R	-d1	-R	-d3	-d	-R	-d1	-d2
NPT-Gewinde / Filetage NPT / NPT thread										
M 8 x 1	10			-3	-1/8NPT					
M 8 x 1	10			-4	-1/8NPT					
M 8 x 1	10			-5	-1/8NPT					
M10x1	12						-4	-1/8NPT	-4	-4
M10x1	14			-4	-1/4NPT	-4	-4	-1/4NPT	-4	-4
M10x1	12						-5	-1/8NPT	-5	-5
M10x1	14			-5	-1/4NPT	-5	-5	-1/4NPT	-5	-5
M10x1	12			-6	-1/8NPT	-6	-6	-1/8NPT	-6	-6
M10x1	14			-6	-1/8NPT	-6	-6	-1/4NPT	-6	-6
M12x1										
M12x1	14			-8	-1/4NPT	-8	-8	-1/4NPT	-8	-8
M14x1	17			-10	-1/4NPT	-10	-10	-1/4NPT	-10	-10
M14x1	17						-10	-3/8NPT	-10	-10
M16x1	22			-10	-1/2NPT	-10				
M16x1	19	-12	-1/4NPT	-12	-1/4NPT	-12	-12	-1/4NPT	-12	-12
M16x1	19			-12	-3/8NPT	-12	-12	-3/8NPT	-12	-12
M16x1	22			-12	-1/2NPT	-12	-12	-1/2NPT	-12	-12
M20x1,5	24			-14	-1/2NPT	-14	-14	-1/2NPT	-14	-14
M20x1,5	24			-15	-1/2NPT	-15	-15	-1/2NPT	-15	-15

Anschlussvarianten mit Übergangsnippel

Variantes de raccordement avec adaptateur mâle

Connections with male adaptor

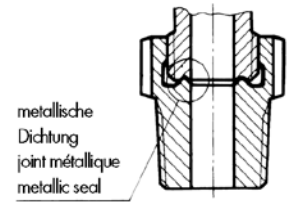
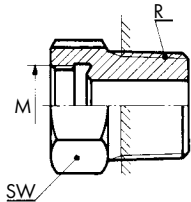
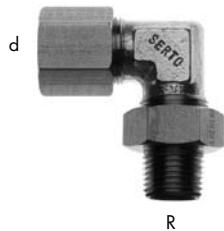
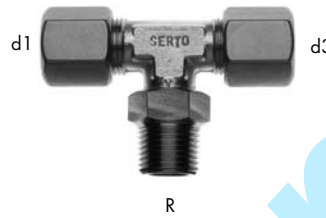
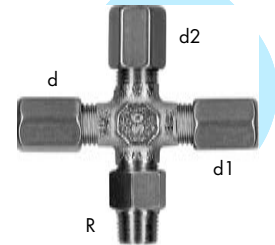
S0 50040

S0 52121

S0 53121

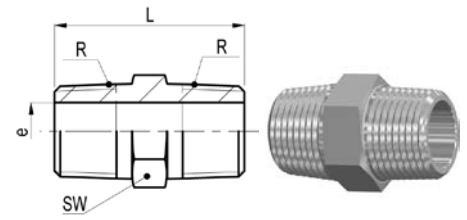
S0 54121

M	SW	-R	-d	-R	-d1	-R	-d3	-d	-R	-d1	-d2
Für Zollrohre / Pour tubes en pouces / For inch tubes											
M10x1	12	-1/8			-6,35	-1/8	-6,35	-6,35	-1/8	-6,35	-6,35
M10x1	14	-1/4			-6,35	-1/4	-6,35	-6,35	-1/4	-6,35	-6,35
M14x1	17	-1/4			-9,52	-1/4	-9,52	-9,52	-1/4	-9,52	-9,52
M14x1	17	-3/8	-9,52	-3/8	-9,52	-3/8	-9,52	-9,52	-3/8	-9,52	-9,52
M14x1	22	-1/2	-9,52	-1/2	-9,52	-1/2	-9,52				
M20x1,5	24	-1/2			-12,7	-1/2	-12,7	-12,7	-1/2	-12,7	-12,7
M24x1,5	30	-1/2	-17,2	-1/2	-17,2	-1/2	-17,2				
M28x1,5	36	-3/4	-21,3	-3/4	-21,3	-3/4	-21,3				
M10x1	17	-1/8			-6,35	-1/8NPT	-6,35	-6,35	-1/8NPT	-6,35	-6,35
M10x1	17	-1/4			-6,35	-1/4NPT	-6,35	-6,35	-1/4NPT	-6,35	-6,35
M14x1	19	-1/4			-9,52	-1/4NPT	-9,52	-9,52	-1/4NPT	-9,52	-9,52
M14x1	19	-1 1/2						-9,52	-1 1/2NPT	-9,52	-9,52
M20x1,5	24	-1/2			-12,7	-1/2NPT	-12,7	-12,7	-1/2NPT	-12,7	-12,7
M20x1,5	24	-1/2			-13,5	-1/2NPT	-13,5	-12,7	-1/2NPT	-12,7	-12,7

Doppelnippel Mamelon double Hex nipple



AD HN 50

Type -R	Mat.-Nr.	SW	L	e	kg/100
AD HN 50-1/8-1/8	TAD.5110.042	12	25.0	6.0	1.005
AD HN 50-1/4-1/4	TAD.5110.104	14	31.0	8.0	1.979
AD HN 50-3/8-3/8	TAD.5110.166	17	33.0	10.5	3.180
AD HN 50-1/2-1/2	TAD.5110.228	22	43.0	13.0	6.749
AD HN 50-3/4-3/4	TAD.5110.292	27	48.0	21.0	7.285
AD HN 50-1-1	TAD.5110.414	36	52.0	26.0	13.822

Übergangsnippel R-NPT Mamelon double inégal R-NPT Conversion hex nipple R-NPT

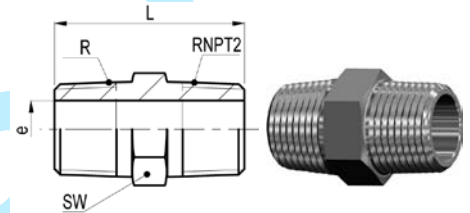

AD HN 50 R-NPT

Type -R-RNPT2	Mat.-Nr.	SW	L	e	kg/100
RNPT2=NPT Gewinde	RNPT2=Filetage NPT			RNPT2=NPT thread	
AD HN 50-1/8-1/8 NPT	TAD.5114.042	12	25.0	6.0	1.067
AD HN 50-1/4-1/4 NPT	TAD.5114.104	14	31.0	8.0	2.061
AD HN 50-3/8-3/8 NPT	TAD.5114.166	17	33.0	10.5	3.260
AD HN 50-1/2-1/2 NPT	TAD.5114.228	22	43.0	13.0	6.850
AD HN 50-3/4-3/4 NPT	TAD.5114.292	27	48.0	21.0	7.371
AD HN 50-1-1 NPT	TAD.5114.414	36	52.0	26.0	13.760

Doppelnippel NPT-NPT Mamelon double NPT-NPT Hex nipple NPT-NPT

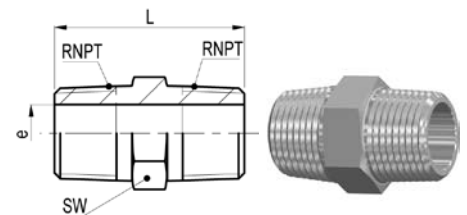

AD HN 50 NPT-NPT

Type -RNPT	Mat.-Nr.	SW	L	e	kg/100
RNPT=NPT Gewinde	RNPT=Filetage NPT			RNPT=NPT thread	
AD HN 50-1/8 NPT-1/8 NPT	TAD.5111.042	12	25.0	6.0	1.113
AD HN 50-1/4 NPT-1/4 NPT	TAD.5111.104	14	31.0	8.0	2.141
AD HN 50-3/8 NPT-3/8 NPT	TAD.5111.166	17	33.0	10.5	3.340
AD HN 50-1/2 NPT-1/2 NPT	TAD.5111.228	22	43.0	13.0	6.949
AD HN 50-3/4 NPT-3/4 NPT	TAD.5111.292	27	48.0	21.0	7.457
AD HN 50-1 NPT-1 NPT	TAD.5111.414	36	52.0	26.0	13.698

Doppelnippel reduziert
Mamelon double réduit
Hex reducing nipple

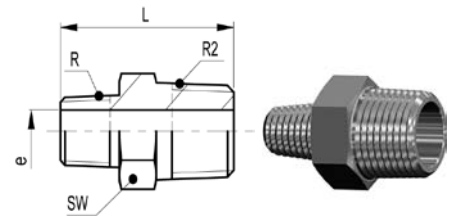
AD HRN 50

Type -R-R2	Mat.-Nr.	SW	L	e	kg/100
AD HRN 50- $\frac{1}{8}$ - $\frac{1}{4}$	TAD.5110.044	14	28.0	6.0	1.830
AD HRN 50- $\frac{1}{8}$ - $\frac{3}{8}$	TAD.5110.046	17	30.0	6.0	3.193
AD HRN 50- $\frac{1}{8}$ - $\frac{1}{2}$	TAD.5110.048	22	35.0	6.0	6.344
AD HRN 50- $\frac{1}{4}$ - $\frac{3}{8}$	TAD.5110.106	17	33.0	8.0	3.308
AD HRN 50- $\frac{1}{4}$ - $\frac{1}{2}$	TAD.5110.108	22	38.0	8.0	6.385
AD HRN 50- $\frac{3}{8}$ - $\frac{1}{2}$	TAD.5110.168	22	38.0	10.5	6.128
AD HRN 50- $\frac{1}{2}$ - $\frac{3}{4}$	TAD.5110.232	27	46.5	13.0	11.548
AD HRN 50- $\frac{1}{2}$ -1	TAD.5110.236	36	48.5	13.0	20.172
AD HRN 50- $\frac{3}{4}$ -1	TAD.5110.296	36	50.0	21.0	15.600

Rohrdoppelnippel
Adaptateur mâle
Barrel nipple

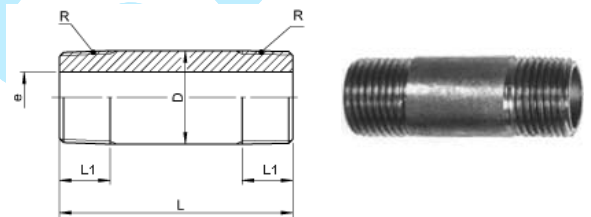
AD CN 50

Type -R	Mat.-Nr.	L	L1	D	e	kg/100
AD CN 50- $\frac{1}{8}$ X40	TAD.5150.021	40.0	8.0	10.0	6.0	1.400
AD CN 50- $\frac{1}{8}$ X60	TAD.5150.023	60.0	8.0	10.0	6.0	2.200
AD CN 50- $\frac{1}{4}$ X40	TAD.5150.042	40.0	9.0	14.0	9.0	2.400
AD CN 50- $\frac{1}{4}$ X60	TAD.5150.045	60.0	9.0	14.0	9.0	2.860
AD CN 50- $\frac{1}{4}$ X80	TAD.5150.049	80.0	9.0	14.0	9.0	5.700
AD CN 50- $\frac{1}{4}$ X100	TAD.5150.053	100.0	9.0	14.0	9.0	7.100
AD CN 50- $\frac{1}{4}$ X150	TAD.5150.058	150.0	9.0	14.0	9.0	8.000
AD CN 50- $\frac{3}{8}$ x60	TAD.5150.060	60.0	12.0	17.0	12.0	4.000
AD CN 50- $\frac{1}{2}$ X40	TAD.5150.082	40.0	13.0	21.0	16.0	3.600
AD CN 50- $\frac{1}{2}$ X60	TAD.5150.084	60.0	13.0	21.0	16.0	5.970
AD CN 50- $\frac{1}{2}$ X80	TAD.5150.086	80.0	13.0	21.0	16.0	8.100
AD CN 50- $\frac{1}{2}$ X100	TAD.5150.088	100.0	13.0	21.0	16.0	11.050
AD CN 50- $\frac{1}{2}$ X150	TAD.5150.093	150.0	13.0	21.0	16.0	15.900
AD CN 50- $\frac{3}{4}$ X80	TAD.5150.126	80.0	17.0	27.0	20.0	10.850
AD CN 50- $\frac{3}{4}$ X100	TAD.5150.128	100.0	17.0	27.0	20.0	12.800
AD CN 50- $\frac{3}{4}$ X150	TAD.5150.134	150.0	17.0	27.0	20.0	20.300
AD CN 50-1 X60	TAD.5150.162	60.0	17.0	34.0	28.0	11.600
AD CN 50-1 X80	TAD.5150.164	80.0	17.0	34.0	28.0	13.300
AD CN 50-1 X100	TAD.5150.166	100.0	17.0	34.0	28.0	14.900
AD CN 50-1 X150	TAD.5150.171	150.0	17.0	34.0	28.0	32.200
AD CN 50-1 X180	TAD.5150.174	180.0	17.0	34.0	28.0	38.600
AD CN 50-1 X200	TAD.5150.176	200.0	17.0	34.0	28.0	43.700

Rohrnippel

kurz

Mamelon

court

Double nipple

short

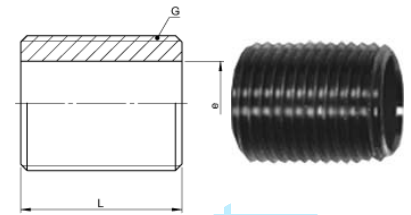

AD CNS 50

Type -G	Mat.-Nr.	L	e	kg/100
AD CNS 50- $\frac{1}{4}$	TAD.5180.104	18.0	9.0	0.600
AD CNS 50- $\frac{3}{8}$	TAD.5180.166	22.0	12.0	1.070
AD CNS 50- $\frac{1}{2}$	TAD.5180.228	25.0	16.0	1.440
AD CNS 50- $\frac{3}{4}$	TAD.5180.292	30.0	22.0	2.650

Rohranschweissnippel

Raccord à souder

Weld-on nipple

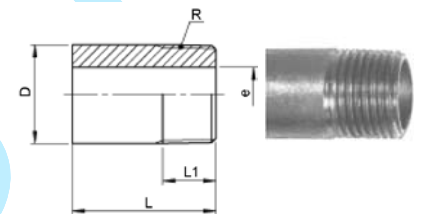

AD CNW 50

Type -R	Mat.-Nr.	L	l1	D	e	kg/100
AD CNW 50- $\frac{1}{8}$	TAD.5170.020	30.0		10.0	6.0	0.900
AD CNW 50- $\frac{1}{4}$	TAD.5170.040	30.0		13.5	9.0	1.100
AD CNW 50- $\frac{3}{8}$	TAD.5170.060	30.0		17.0	12.0	1.760
AD CNW 50- $\frac{1}{2}$	TAD.5170.080	35.0		21.0	16.5	3.600
AD CNW 50- $\frac{3}{4}$	TAD.5170.120	40.0		27.0	21.5	5.200
AD CNW 50-1	TAD.5170.160	40.0		34.0	28.0	5.250

Rohranschweissnippel NPT

Raccord à souder NPT

Weld-on nipple NPT

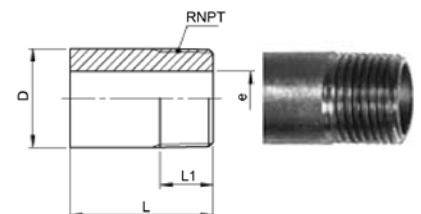

AD CNW 50 NPT

Type -RNPT	Mat.-Nr.	L	l1	D	e	kg/100
RNPT=NPT Gewinde	RNPT=Filetage NPT					RNPT=NPT thread
AD CNW 50- $\frac{1}{8}$ NPT	TAD.5171.020	30.0	8.5	10.0	6.0	0.720
AD CNW 50- $\frac{1}{4}$ NPT	TAD.5171.040	30.0	12.5	13.5	8.8	1.140
AD CNW 50- $\frac{3}{8}$ NPT	TAD.5171.060	30.0	12.0	17.0	12.0	2.100
AD CNW 50- $\frac{1}{2}$ NPT	TAD.5171.080	35.0	13.0	21.0	16.5	2.400
AD CNW 50- $\frac{3}{4}$ NPT	TAD.5171.120	40.0	17.5	27.0	22.0	3.320
AD CNW 50-1 NPT	TAD.5171.160	40.0	21.0	33.5	27.5	5.010

Edelstahl

Acier inoxydable

Stainless steel

Adapter
Adaptateur
Adapter

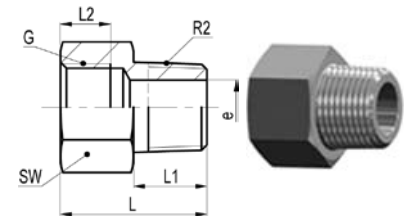

AD A 50

Type -G-R2	Mat.-Nr.	SW	L	L1	L2	e	kg/100
AD A 50-1/8-1/8	TAD.5120.042	14	21.0	9.5	8.0	6.0	1.226
AD A 50-1/4-1/4	TAD.5120.104	17	26.0	12.5	9.0	8.0	2.192
AD A 50-3/8-3/8	TAD.5120.166	22	27.0	12.5	9.5	10.5	3.698
AD A 50-1/2-1/2	TAD.5120.228	27	35.0	17.5	11.5	13.0	7.183
AD A 50-3/4-3/4	TAD.5120.292	32	40.0	19.0	14.0	21.0	9.166
AD A 50-1-1	TAD.5120.414	41	45.0	21.0	17.0	26.0	17.524

Adapter reduziert
Adaptateur réduit
Reducing adapter

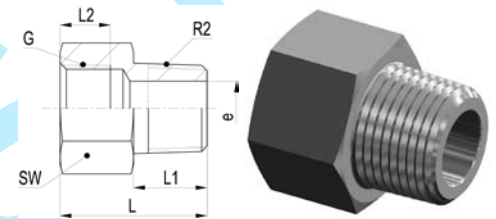

AD RA 50 G-R

Type -G-R2	Mat.-Nr.	SW	L	L1	L2	e	kg/100
AD RA 50-1/4-1/8	TAD.5120.102	17	23.0	9.5	9.0	6.0	1.776
AD RA 50-3/8-1/4	TAD.5120.164	22	28.0	12.5	9.5	8.0	3.586
AD RA 50-1/2-1/4	TAD.5120.224	27	31.0	12.5	11.5	8.0	5.815
AD RA 50-1/2-3/8	TAD.5120.226	27	30.0	12.5	11.5	10.5	5.780
AD RA 50-3/4-1/2	TAD.5120.288	32	39.0	17.5	14.0	13.0	9.662
AD RA 50-1-1/2	TAD.5120.408	41	45.0	17.5	17.0	13.0	18.781
AD RA 50-1-3/4	TAD.5120.412	41	45.0	19.0	17.0	21.0	17.126

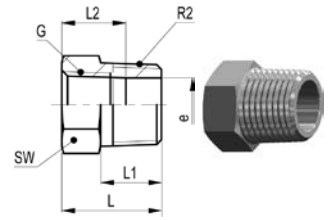
Reduziernippel
Réduction
Hex bushing

AD RB 50 G-R

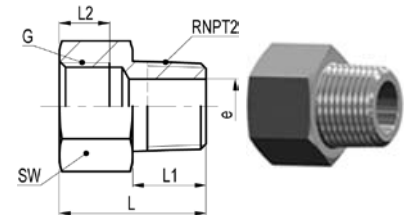
Type -G-R2	Mat.-Nr.	SW	L	L1	L2	e	kg/100
AD RB 50-1/8-1/4	TAD.5130.044	14	18.5	12.5	8.0	8.6	1.139
AD RB 50-1/8-3/8	TAD.5130.046	17	20.5	12.5	8.0	8.6	2.456
AD RB 50-1/8-1/2	TAD.5130.048	22	25.5	17.5	8.0	8.6	5.502
AD RB 50-1/4-3/8	TAD.5130.106	17	20.5	12.5	9.0	11.4	1.798
AD RB 50-1/4-1/2	TAD.5130.108	22	25.5	17.5	9.0	11.4	4.693
AD RB 50-1/4-3/4	TAD.5130.110	27	29.0	19.0	9.0	11.4	9.574
AD RB 50-3/8-1/2	TAD.5130.168	22	25.5	17.5	9.5	15.0	3.939
AD RB 50-3/8-3/4	TAD.5130.170	27	29.0	19.0	9.5	15.0	7.647
AD RB 50-3/8-1	TAD.5130.172	36	31.0	21.0	9.5	15.0	16.634
AD RB 50-1/2-3/4	TAD.5130.232	27	29.0	19.0	11.5	18.6	6.079
AD RB 50-1/2-1	TAD.5130.236	36	31.0	21.0	11.5	18.6	14.496
AD RB 50-3/4-1	TAD.5130.296	36	31.0	21.0	14.0	24.1	10.487

Übergangs-Adapter G-NPT
Adaptateur inégal G-NPT
Conversion adapter G-NPT

AD A 50 G-NPT

Type -G-RNPT2	Mat.-Nr.	SW	L	L1	L2	e	kg/100
RNPT2=NPT Gewinde							
		RNPT2=Filetage NPT				RNPT2=NPT thread	
AD A 50-1/8-1/8 NPT	TAD.5124.042	14	21.0	9.5	8.0	6.0	1.277
AD A 50-1/4-1/4 NPT	TAD.5124.104	17	26.0	12.5	9.0	8.0	2.271
AD A 50-3/8-3/8 NPT	TAD.5124.166	22	27.0	12.5	9.5	10.5	3.786
AD A 50-1/2-1/2 NPT	TAD.5124.228	27	35.0	17.5	11.5	13.0	7.280
AD A 50-3/4-3/4 NPT	TAD.5124.292	32	40.0	19.0	14.0	21.0	9.252
AD A 50-1-1 NPT	TAD.5124.414	41	45.0	21.0	17.0	26.0	17.482

Übergangs-Adapter reduziert G-NPT

Adaptateur inégal réduit G-NPT

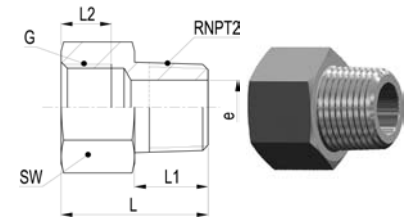
Conversion reducing adapter G-NPT



AD RA 50 G-NPT

Type -G-RNPT2	Mat.-Nr.	SW	L	L1	L2	e	kg/100
RNPT2=NPT Gewinde		RNPT2=Filetage NPT			RNPT2=NPT thread		
AD RA 50-1/4-1/8 NPT	TAD.5124.102	17	23.0	9.5	9.0	6.0	1.827
AD RA 50-3/8-1/4 NPT	TAD.5124.164	22	28.0	12.5	9.5	8.0	3.666
AD RA 50-1/2-1/4 NPT	TAD.5124.224	27	31.0	12.5	11.5	8.0	5.895
AD RA 50-1/2-3/8 NPT	TAD.5124.226	27	30.0	12.5	11.5	10.5	5.868
AD RA 50-3/4-1/2 NPT	TAD.5124.288	32	39.0	17.5	14.0	13.0	9.759
AD RA 50-1-3/4 NPT	TAD.5124.412	41	45.0	19.0	17.0	21.0	17.213

Übergangs-Reduziernippel G-NPT

Réduction inégale G-NPT

Conversion hex bushing G-NPT

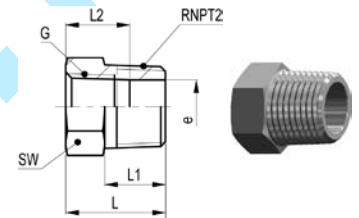

AD RB 50 G-NPT

Type -G-RNPT2	Mat.-Nr.	SW	L	L1	L2	e	kg/100
RNPT2=NPT Gewinde		RNPT2=Filetage NPT			RNPT2=NPT thread		
AD RB 50-1/8-1/4 NPT	TAD.5134.044	14	18.5	12.5	8.0	8.6	1.220
AD RB 50-1/8-3/8 NPT	TAD.5134.046	17	20.5	12.5	8.0	8.6	2.537
AD RB 50-1/8-1/2 NPT	TAD.5134.048	22	25.5	17.5	8.0	8.6	5.600
AD RB 50-1/4-3/8 NPT	TAD.5134.106	17	20.5	12.5	9.0	11.4	1.879
AD RB 50-1/4-1/2 NPT	TAD.5134.108	22	25.5	17.5	9.0	11.4	4.791
AD RB 50-1/4-3/4 NPT	TAD.5134.110	27	29.0	19.0	9.0	11.4	9.660
AD RB 50-3/8-1/2 NPT	TAD.5134.168	22	25.5	17.5	9.5	15.0	3.490
AD RB 50-1/2-3/4 NPT	TAD.5134.232	27	29.0	19.0	11.5	18.6	6.165
AD RB 50-3/4-1 NPT	TAD.5134.296	36	31.0	21.0	14.0	24.1	10.445

Übergangs-Adapter NPT-R

Adaptateur inégal NPT-R

Conversion adapter NPT-R

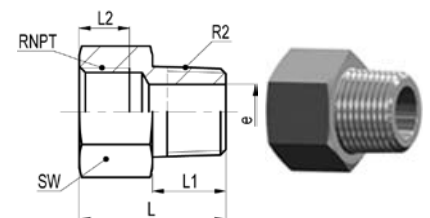

AD A 50 NPT-R

Type -RNPT-R2	Mat.-Nr.	SW	L	L1	L2	e	kg/100
RNPT=NPT Gewinde		RNPT=Filetage NPT			RNPT=NPT thread		
AD A 50-1/8 NPT-1/8	TAD.5125.042	14	21.0	9.5	10.0	6.0	1.239
AD A 50-1/4 NPT-1/4	TAD.5125.104	17	29.0	12.5	14.0	8.0	2.424
AD A 50-3/8 NPT-3/8	TAD.5125.166	22	29.0	12.5	14.0	10.5	3.800
AD A 50-1/2 NPT-1/2	TAD.5125.228	27	38.0	17.5	18.0	13.0	8.108
AD A 50-3/4 NPT-3/4	TAD.5125.292	32	43.0	19.0	20.0	21.0	10.371
AD A 50-1 NPT-1	TAD.5125.414	36	45.0	21.0	23.0	26.0	12.020

Übergangs-Reduziernippel NPT-R

Réduction inégale NPT-R

Conversion hex bushing NPT-R

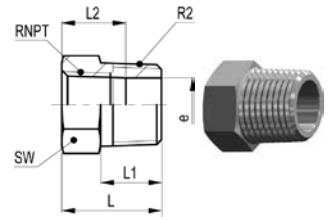

AD RB 50 NPT-R

Type -RNPT -R2	Mat.-Nr.	SW	L	L1	L2	e	kg/100
RNPT=NPT Gewinde	RNPT=Filetage NPT				RNPT=NPT thread		
AD RB 50-1/8 NPT-1/4	TAD.5135.044	14	18.5	12.5	6.7	8.4	1.142
AD RB 50-1/4 NPT-3/8	TAD.5135.106	17	20.5	12.5	10.2	10.8	1.869
AD RB 50-1/4 NPT-1/2	TAD.5135.108	22	25.5	17.5	10.2	10.8	4.802
AD RB 50-1/2 NPT-3/4	TAD.5135.232	27	29.0	19.0	13.5	17.7	6.418

Adapter reduziert NPT-NPT

Adaptateur réduit NPT-NPT

Reducing adapter NPT-NPT

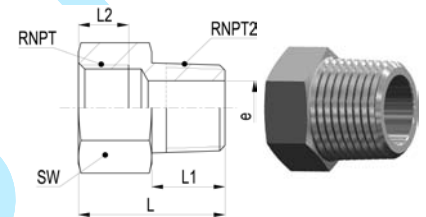

AD RA 50 NPT-NPT

Type -RNPT -RNPT2	Mat.-Nr.	SW	L	L1	L2	e	kg/100
RNPT=NPT Gewinde	RNPT=Filetage NPT				RNPT=NPT thread		
RNPT2=NPT Gewinde	RNPT2=Filetage NPT				RNPT2=NPT thread		
AD RA 50-1/4 NPT -1/8 NPT	TAD.5121.102	17	26.0	9.5	10.2	6.0	2.150
AD RA 50-3/8 NPT -1/4 NPT	TAD.5121.164	22	30.0	12.5	10.3	8.0	3.920
AD RA 50-1/2 NPT -1/4 NPT	TAD.5121.224	27	35.0	12.5	13.5	8.0	7.505
AD RA 50-1/2 NPT -3/8 NPT	TAD.5121.226	27	35.0	12.5	13.5	10.5	7.866
AD RA 50-3/4 NPT -1/2 NPT	TAD.5121.288	32	43.0	17.5	13.8	13.0	12.030
AD RA 50-1 NPT -1/2 NPT	TAD.5121.408	36	48.0	17.5	17.4	13.0	14.540
AD RA 50-1 NPT -3/4 NPT	TAD.5121.412	36	48.0	19.0	17.4	21.0	13.110

Reduziernippel NPT-NPT

Réduction NPT-NPT

Hex bushing NPT-NPT

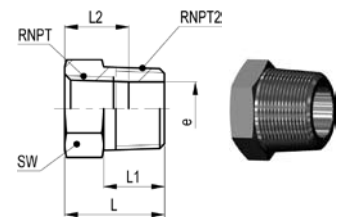

AD RB 50 NPT-NPT

Type -RNPT -RNPT2	Mat.-Nr.	SW	L	L1	L2	e	kg/100
RNPT=NPT Gewinde	RNPT=Filetage NPT				RNPT=NPT thread		
RNPT2=NPT Gewinde	RNPT2=Filetage NPT				RNPT2=NPT thread		
AD RB 50-1/8 NPT -1/4 NPT	TAD.5131.044	14	18.5	12.5	6.7	8.4	1.280
AD RB 50-1/8 NPT -3/8 NPT	TAD.5131.046	17	20.5	12.5	6.7	8.4	2.660
AD RB 50-1/4 NPT -3/8 NPT	TAD.5131.106	17	20.5	12.5	10.2	10.8	2.070
AD RB 50-1/4 NPT -1/2 NPT	TAD.5131.108	22	25.5	17.5	10.2	10.8	5.150
AD RB 50-3/8 NPT -1/2 NPT	TAD.5131.168	22	25.5	17.5	10.3	13.9	3.980
AD RB 50-1/2 NPT -3/4 NPT	TAD.5131.232	27	29.0	19.0	13.5	17.7	6.820
AD RB 50-1/2 NPT -1 NPT	TAD.5131.236	36	31.0	21.0	13.5	17.7	15.510
AD RB 50-3/4 NPT -1 NPT	TAD.5131.296	36	31.0	21.0	13.8	22.5	11.920

Edelstahl

Acier inoxydable

Stainless steel

Muffe
Manchon
Adaptor

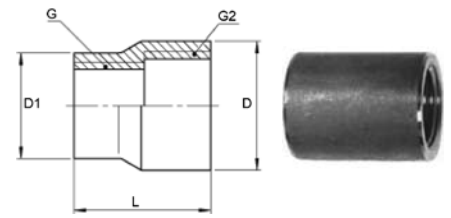

AD C 50

Type -G-G2	Mat.-Nr.	L	D	D1	kg/100
AD C 50-1/8-1/8	TAD.5140.042	17.0	14.0		1.150
AD C 50-1/8-1/4	TAD.5140.044	25.0	18.0	15.0	2.540
AD C 50-1/4-1/4	TAD.5140.104	25.0	18.0		2.150
AD C 50-1/4-3/8	TAD.5140.106	30.0	22.5	17.5	5.140
AD C 50-1/4-1/2	TAD.5140.108	37.0	28.0	18.0	8.600
AD C 50-3/8-3/8	TAD.5140.166	27.0	22.0		3.600
AD C 50-3/8-1/2	TAD.5140.168	34.0	28.0	22.0	7.660
AD C 50-1/2-1/2	TAD.5140.228	34.0	27.0		5.760
AD C 50-1/2-3/4	TAD.5140.232	39.0	33.0	27.0	13.860
AD C 50-3/4-3/4	TAD.5140.292	36.0	33.0		8.600
AD C 50-3/4-1	TAD.5140.296	45.0	40.0	33.0	26.340
AD C 50-3/4-1 1/4	TAD.5140.298	50.0	50.0	33.0	29.310
AD C 50-1-1	TAD.5140.414	43.0	40.0		15.250
AD C 50-1-1 1/4	TAD.5140.418	50.0	50.0	40.0	34.420

Halbe Muffe
Manchon court
Coupling short

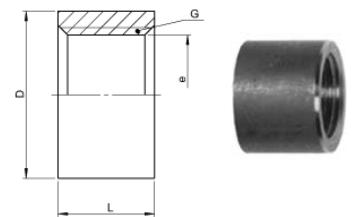

AD CS 50

Type -G	Mat.-Nr.	L	D	kg/100
AD CS 50-1/8	TAD.5200.042	8.0	14.0	
AD CS 50-1/4	TAD.5200.104	11.0	17.0	0.900
AD CS 50-3/8	TAD.5200.166	12.0	22.0	1.550
AD CS 50-1/2	TAD.5200.228	15.0	27.0	2.600
AD CS 50-3/4	TAD.5200.292	17.0	32.0	3.670
AD CS 50-1	TAD.5200.414	19.0	40.0	6.100

Hochdruckanschweissmuffe

Manchon haute pression à souder

High-pressure weld-on adaptor

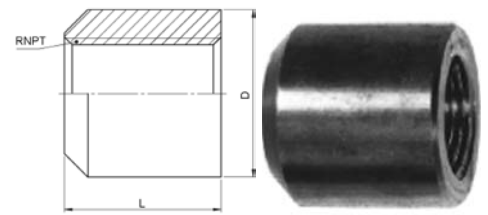

AD FCW 50

Type -RNPT	Mat.-Nr.	L	D	kg/100
RNPT=NPT Gewinde	RNPT=Filetage NPT		RNPT=NPT thread	
AD FCW 50-1/8 NPT	TAD.5161.042	21.0	20.0	1.250
AD FCW 50-1/4 NPT	TAD.5161.104	25.0	25.0	2.160
AD FCW 50-3/8 NPT	TAD.5161.166	30.0	25.0	7.000
AD FCW 50-1/2 NPT	TAD.5161.228	30.0	32.0	7.240
AD FCW 50-1 NPT	TAD.5161.414	40.0	50.0	37.400

Sechskant-Muffe

Manchon double

Hex coupling

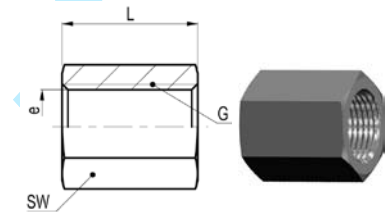

AD HC 50

Type -G	Mat.-Nr.	SW	L	e	kg/100
AD HC 50-1/8-1/8	TAD.5100.042	17	17.0	8.6	2.278
AD HC 50-1/4-1/4	TAD.5100.104	22	25.0	11.4	5.500
AD HC 50-3/8-3/8	TAD.5100.166	22	26.0	15.0	4.391
AD HC 50-1/2-1/2	TAD.5100.228	27	34.0	18.6	8.425
AD HC 50-3/4-3/4	TAD.5100.292	32	36.0	24.1	10.686
AD HC 50-1-1	TAD.5100.414	46	43.0	30.3	33.192

Sechskant-Muffe reduziert

Manchon double réduit

Hex reducing coupling

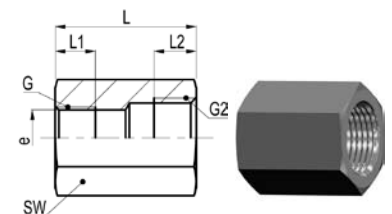

AD HRC 50

Type -G -G2	Mat.-Nr.	SW	L	L1	L2	e	kg/100
AD HRC 50-1/8-1/4	TAD.5100.044	22	25.0	8.0	9.0	8.6	5.938
AD HRC 50-1/8-3/8	TAD.5100.046	22	30.0	8.0	9.5	8.6	6.500
AD HRC 50-1/8-1/2	TAD.5100.048	27	41.0	8.0	11.5	8.6	14.097
AD HRC 50-1/4-3/8	TAD.5100.106	22	29.0	9.0	9.5	11.4	5.746
AD HRC 50-1/4-1/2	TAD.5100.108	27	40.0	9.0	11.5	11.4	12.941
AD HRC 50-3/8-1/2	TAD.5100.168	27	38.0	9.5	11.5	15.0	10.055
AD HRC 50-1/2-3/4	TAD.5100.232	32	41.0	11.5	14.0	18.6	15.200
AD HRC 50-1/2-1	TAD.5100.236	46	51.0	11.5	17.0	18.6	48.706

Rohrkappe

Capuchon femelle

Hex cap

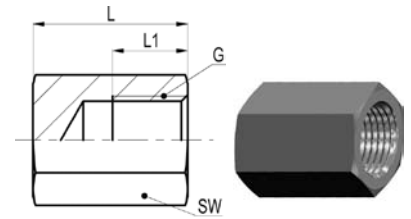

AD HCP 50

Type -G	Mat.-Nr.	SW	L	L1	kg/100
AD HCP 50-1/8	TAD.5000.020	17	19.0	8.0	2.757
AD HCP 50-1/4	TAD.5000.040	22	24.0	9.0	5.932
AD HCP 50-3/8	TAD.5000.060	22	27.0	9.5	5.875
AD HCP 50-1/2	TAD.5000.080	27	37.0	11.5	12.700
AD HCP 50-3/4	TAD.5000.120	32	38.0	14.0	16.363
AD HCP 50-1	TAD.5000.160	46	44.0	17.0	43.193

Verschlussstopfen 6kt

Bouchon mâle

Hex plug

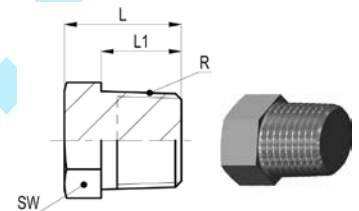

AD HP 50 R

Type -R	Mat.-Nr.	SW	L	L1	kg/100
AD HP 50-1/8	TAD.5020.020	12	15.5	9.5	1.017
AD HP 50-1/4	TAD.5020.040	14	18.5	12.5	1.892
AD HP 50-3/8	TAD.5020.060	17	20.5	12.5	3.289
AD HP 50-1/2	TAD.5020.080	22	25.5	17.5	6.548
AD HP 50-3/4	TAD.5020.120	27	29.0	19.0	11.671
AD HP 50-1	TAD.5020.160	36	31.0	21.0	20.534

Verschlussstopfen 6kt NPT

Bouchon mâle NPT

Hex plug NPT

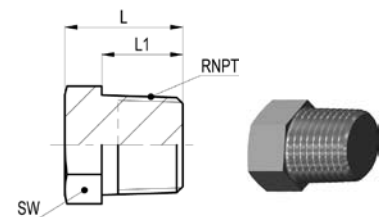

AD HP 50 NPT

Type -RNPT	Mat.-Nr.	SW	L	L1	kg/100
RNPT=NPT Gewinde	RNPT=Filetage NPT			RNPT=NPT thread	
AD HP 50-1/8 NPT	TAD.5021.020	12	15.5	9.5	1.070
AD HP 50-1/4 NPT	TAD.5021.040	14	18.5	12.5	1.973
AD HP 50-3/8 NPT	TAD.5021.060	17	20.5	12.5	3.370
AD HP 50-1/2 NPT	TAD.5021.080	22	25.5	17.5	6.647
AD HP 50-3/4 NPT	TAD.5021.120	27	29.0	19.0	11.756
AD HP 50-1 NPT	TAD.5021.160	36	31.0	21.0	20.472

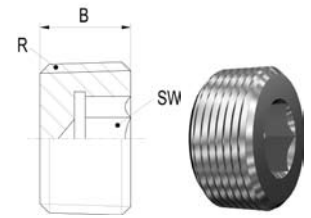
Verschlusschraube mit Innen 6kt
Bouchon d'obturation
Screw Plug

AD SP 50

Type -R	Mat.-Nr.	SW	B	kg/100
AD SP 50-1/8	TAD.5010.020	5	8.0	0.338
AD SP 50-1/4	TAD.5010.040	7	10.0	0.740
AD SP 50-3/8	TAD.5010.060	8	10.0	1.250
AD SP 50-1/2	TAD.5010.080	10	10.0	1.940
AD SP 50-3/4	TAD.5010.110	12	12.0	3.800
AD SP 50-1	TAD.5010.160	17	12.0	5.760

Verschlusschraube

mit Aussen-6kt und Bund

Vis d'extrémité

six pans extérieur

Screw plug

hexagon head

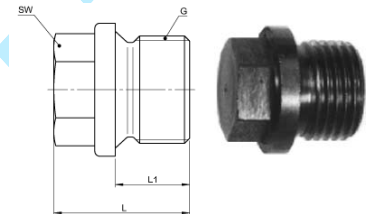
AD HPS 50

Type -G	Mat.-Nr.	SW	L	L1	kg/100
AD HPS 50-1/8	TAD.5030.020	10	17.0	8.0	1.160
AD HPS 50-1/4	TAD.5030.040	13	21.0	12.0	2.600
AD HPS 50-3/8	TAD.5030.060	17	21.0	12.0	3.960
AD HPS 50-1/2	TAD.5030.080	19	26.5	14.0	6.960
AD HPS 50-3/4	TAD.5030.120	24	30.0	16.0	12.620
AD HPS 50-1	TAD.5030.160	27	32.0	16.0	19.900

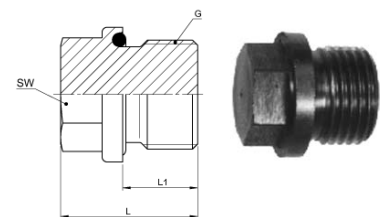
Verschlusschraube mit O-Ring
Bouchon d'obturation avec joint torique
Screw plug with O-Ring

AD HPO 50

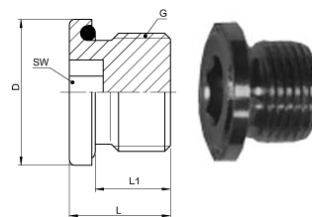
Type -G	Mat.-Nr.	SW	L	L1	kg/100
AD HPO 50-1/8	TAD.5040.020	10	17.0	8.0	1.180
AD HPO 50-1/4	TAD.5040.040	13	21.0	12.0	2.280
AD HPO 50-3/8	TAD.5040.060	17	21.0	12.0	3.780
AD HPO 50-1/2	TAD.5040.080	19	26.0	14.0	7.000

Verschlusschraube mit O-Ring (FPM)
Bouchon d'obturation avec joint torique (FPM)
Screw plug with O-Ring (FPM)

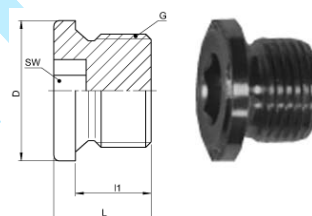
AD HSPO 50

Type -G	Mat.-Nr.	SW	L	L1	D	kg/100
AD HSPO 50-1/8-FPM	TAD.5050.020	5	11.0	8.0	14.0	0.610
AD HSPO 50-1/4-FPM	TAD.5050.040	6	15.0	12.0	18.0	1.410
AD HSPO 50-3/8-FPM	TAD.5050.060	8	15.0	12.0	18.0	2.200
AD HSPO 50-1/2-FPM	TAD.5050.080	10	18.0	14.0	26.0	4.130
AD HSPO 50-3/4-FPM	TAD.5050.120	12	20.0	16.0	32.0	7.380

Verschlusschraube mit Innen-6kt
Vis d'extrémité six pans creux
Hexagon socket screw plug

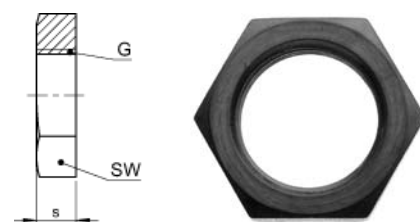
AD HSP 50

Type -G	Mat.-Nr.	SW	L	L1	D	kg/100
AD HSP 50-1/8	TAD.5070.020	5	11.0	8.0	14.0	0.650
AD HSP 50-1/4	TAD.5070.040	6	15.0	12.0	18.0	1.470
AD HSP 50-3/8	TAD.5070.060	8	15.0	12.0	22.0	2.320
AD HSP 50-1/2	TAD.5070.080	10	18.0	14.0	26.0	4.350
AD HSP 50-3/4	TAD.5070.120	12	20.0	16.0	32.0	7.700
AD HSP 50-1	TAD.5070.160	17	21.0	16.0	39.0	12.000

Sechskant-Kontermutter
Ecrou à six pans
Hex counternut

AD HCN 50

Type -G	Mat.-Nr.	SW	s	kg/100
AD HCN 50-1/8	TAD.5900.042	19	6.00	1.200
AD HCN 50-1/4	TAD.5900.104	22	6.00	1.430
AD HCN 50-3/8	TAD.5900.166	27	7.00	2.370
AD HCN 50-1/2	TAD.5900.228	32	8.00	3.000
AD HCN 50-3/4	TAD.5900.292	36	9.00	4.260

Aufschraub-Winkel

Coude double femelle

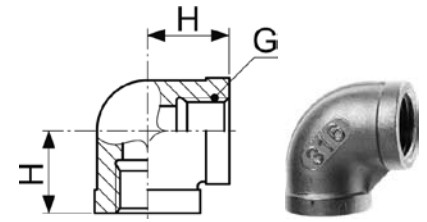
Female elbow



AD FE 51

Type -G	Mat.-Nr.	H	kg/100
AD FE 51-1/8-1/8	TAD.5300.042	20.0	3.700
AD FE 51-1/4-1/4	TAD.5300.104	18.0	5.100
AD FE 51-3/8-3/8	TAD.5300.166	23.0	6.600
AD FE 51-1/2-1/2	TAD.5300.228	27.0	9.000
AD FE 51-3/4-3/4	TAD.5300.292	32.0	19.100
AD FE 51-1-1	TAD.5300.414	33.0	27.800

Einschraub-/Aufschraub-Winkel

Coude femelle - mâle

Street elbow

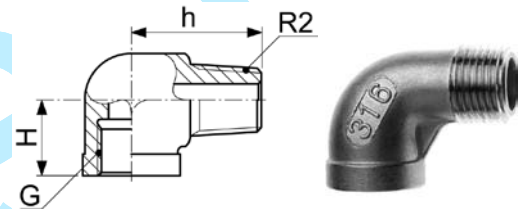

AD SE 51

Type -G -R2	Mat.-Nr.	H	h	kg/100
AD SE 51-1/8-1/8	TAD.5320.042	20.0	26.0	2.800
AD SE 51-1/4-1/4	TAD.5320.104	19.0	30.0	3.600
AD SE 51-3/8-3/8	TAD.5320.166	22.0	35.0	6.500
AD SE 51-1/2-1/2	TAD.5320.228	26.0	41.0	11.200
AD SE 51-3/4-3/4	TAD.5320.292	32.0	40.0	16.100
AD SE 51-1-1	TAD.5320.414	38.0	54.0	25.600

Aufschraub-T

Té triple femelle

Female Tee

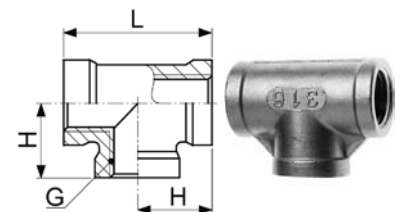

AD FT 51

Type -G	Mat.-Nr.	L	H	kg/100
AD FT 51-1/8-1/8-1/8	TAD.5400.060	42.0	20.0	3.000
AD FT 51-1/4-1/4-1/4	TAD.5400.160	38.0	19.0	7.300
AD FT 51-3/8-3/8-3/8	TAD.5400.350	48.0	24.0	10.100
AD FT 51-1/2-1/2-1/2	TAD.5400.450	54.0	27.0	16.400
AD FT 51-3/4-3/4-3/4	TAD.5400.520	63.0	31.5	22.500
AD FT 51-1-1-1	TAD.5400.650	72.0	36.0	37.000

6kt-Nippel

mit einseitigem 60°-Innenkonus, andere Seite Innengewinde

Raccord six pans

à cône intérieur 60°, filetage intérieur sur un côté

Hexagon nipple

with 60° internal taper on 1 side, internal thread on other

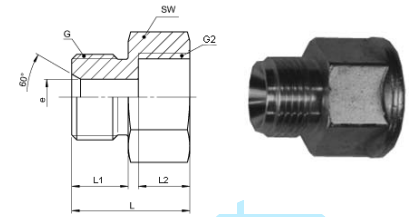

ADH A 50

Type -G -G2	Mat.-Nr.	SW	L	L1	L2	e	kg/100
ADH A 50- $\frac{3}{8}$ - $\frac{3}{8}$	496.5320.166	22	26.0	11.0	10.0	9.0	3.870
ADHA 50- $\frac{1}{2}$ - $\frac{1}{2}$	496.5320.228	27	29.0	12.0	13.0	12.0	6.110

6kt-Doppelnippel

beidseitig 60°-Innenkonus

Raccord six pans

à cône intérieur 60° des deux côtés

Hexagon barrel nipple

60° internal taper on both sides

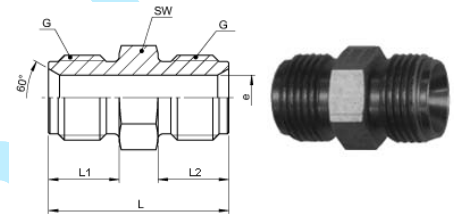

ADH HNC 50

Type -G	Mat.-Nr.	SW	L	L1	L2	e	kg/100
ADH HNC 50- $\frac{1}{4}$ - $\frac{1}{4}$	496.5100.104	17	28.0	11.0	11.0	8.5	1.490
ADH HNC 50- $\frac{3}{8}$ - $\frac{3}{8}$	496.5100.166	14	28.0	11.0	11.0	7.5	2.560

Doppelnippel

mit einseitigem 60°-Innenkonus, andere Seite kegeliges Aussengewind

Raccord double

à cône intérieur 60°, filetage extérieur sur un côté

Barrel nipple

with 60° internal taper on 1 side, tapered external thread on other

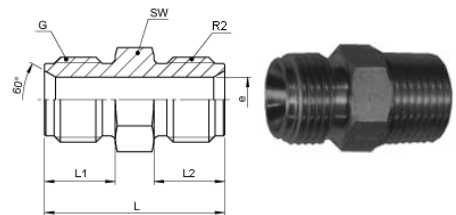

ADH HNIC 50

Type -G -R2	Mat.-Nr.	SW	L	L1	L2	e	kg/100
ADH HNIC 50- $\frac{1}{8}$ - $\frac{1}{8}$	496.5210.042	10	22.0	10.0	8.0	4.0	0.760
ADH HNIC 50- $\frac{1}{4}$ - $\frac{1}{4}$	496.5210.104	14	28.0	10.0	11.0	7.5	1.120
ADH HNIC 50- $\frac{3}{8}$ - $\frac{3}{8}$	496.5210.166	17	30.0	11.0	12.0	10.0	3.280
ADH HNIC 50- $\frac{1}{2}$ - $\frac{1}{2}$	496.5210.228	22	34.0	11.5	13.0	12.0	5.480
ADH HNIC 50- $\frac{3}{4}$ - $\frac{3}{4}$	496.5210.292	27	38.0	13.0	15.0	17.0	9.000

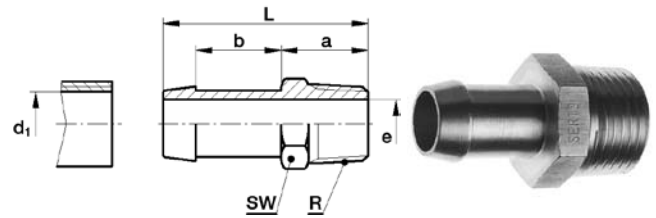
Einschraubtülle
Douille canellée à visser
Male adaptor hose nozzle

SO 50511

Type -d1 -R	Mat.-Nr.	SW	L	a	b	e	kg/100
R=Rohrgewinde (kegelig)	R=Filetage-gaz BSP (conique)					R=BSP thread (tapered)	
SO 50511-4-1/8	056.0511.060	10	23.0	12.0	8.0	3.0	0.700
SO 50511-4-1/4	056.0511.065	14	28.5	17.5	8.0	3.0	1.540
SO 50511-6-1/8	056.0511.100	10	29.0	12.0	12.0	4.0	0.910
SO 50511-6-1/4	056.0511.110	14	34.5	17.5	12.0	4.0	1.710
SO 50511-6-3/8	056.0511.120	17	35.0	18.0	12.0	4.0	2.400
SO 50511-6-1/2	056.0511.125	22	40.0	23.0	12.0	4.0	4.130
SO 50511-8-1/8	056.0511.160	10	29.0	12.0	12.0	6.0	9.710
SO 50511-8-1/4	056.0511.170	14	34.5	17.5	12.0	6.0	1.740
SO 50511-8-3/8	056.0511.180	17	35.0	18.0	12.0	6.0	2.500
SO 50511-8-1/2	056.0511.185	22	40.0	23.0	12.0	6.0	4.220
SO 50511-10-1/4	056.0511.270	14	36.5	17.5	14.0	7.0	1.540
SO 50511-10-3/8	056.0511.280	17	37.0	18.0	14.0	7.0	3.030
SO 50511-10-1/2	056.0511.285	22	42.0	23.0	14.0	7.0	4.470
SO 50511-12.7-1/4	056.0511.380	17	52.0	19.0	8.0	8.0	4.300
SO 50511-13-3/8	056.0511.450	17	39.0	18.0	15.0	10.0	3.730
SO 50511-13-1/2	056.0511.454	22	44.0	23.0	15.0	10.0	5.320
SO 50511-16-1/2	056.0511.566	22	49.0	23.0	18.0	13.0	5.930
SO 50511-19-1/2	056.0511.676	22	49.0	23.0	18.0	16.0	7.340
SO 50511-19-3/4	056.0511.678	27	51.0	25.0	18.0	16.0	10.550
SO 50511-25-1"	056.0511.810	36	59.0	30.0	19.0	22.0	17.160

d1=entspricht dem Innen-Ø des Schlauches

d1=correspond au Ø intérieur du tuyau

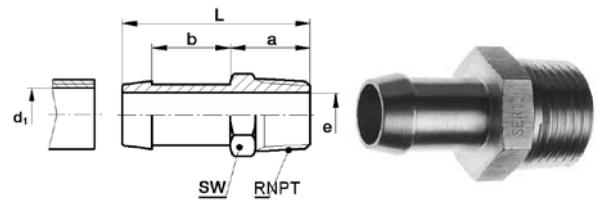
d1=corresponds to the inside diameter of the hose

Einschraubtülle NPT
Douille canellée à visser NPT
Male adaptor hose nozzle NPT

SO 50511 NPT

Type -d1 -RNPT	Mat.-Nr.	SW	L	a	b	e	kg/100
RNPT=NPT Gewinde	RNPT=Filetage NPT			RNPT=NPT thread			
SO 50511-4-1/8 NPT	056.0512.060	12	25.5	14.5	8.0	3.0	1.000
SO 50511-4-1/4 NPT	056.0512.065	14	30.5	19.5	8.0	3.0	1.990
SO 50511-6-1/8 NPT	056.0512.100	12	31.5	14.5	12.0	4.0	1.200
SO 50511-6-1/4 NPT	056.0512.110	14	36.5	19.5	12.0	4.0	2.190
SO 50511-8-1/8 NPT	056.0512.160	12	31.5	14.5	12.0	6.0	1.170
SO 50511-8-1/4 NPT	056.0512.170	14	36.5	19.5	12.0	6.5	2.180
SO 50511-10-1/4 NPT	056.0512.270	14	38.5	19.5	14.0	7.0	2.500
SO 50511-10-3/8 NPT	056.0512.280	17	39.0	20.0	14.0	7.0	2.700
SO 50511-10-1/2 NPT	056.0512.285	22	45.0	26.0	14.0	7.0	5.530
SO 50511-13-3/8 NPT	056.0512.450	17	41.0	20.0	15.0	10.0	3.600
SO 50511-13-1/2 NPT	056.0512.454	22	47.0	26.0	15.0	10.0	5.830
SO 50511-16-1/2 NPT	056.0512.566	22	52.0	26.0	18.0	13.0	6.620
SO 50511-19-1/2 NPT	056.0512.676	22	52.0	26.0	18.0	14.0	6.460
SO 50511-19-3/4 NPT	056.0512.678	30	55.0	29.0	18.0	16.0	10.330
SO 50511-25-3/4 NPT	056.0512.805	30	59.0	29.0	20.0	19.0	9.850
SO 50511-25-1 NPT	056.0512.810	36	63.0	33.0	20.0	22.0	16.500

d1=entspricht dem Innen-Ø des Schlauches

d1=correspond au Ø intérieur du tuyau

d1=corresponds to the inside diameter of the hose